

VIKING ACCESS SYSTEMS™

installation instructions

and safety information



class I, class III, and class IV
residential vehicular slide gate operator



The K-2™ slide gate operator raises the bar in quality for the residential market. This machine operates a highly efficient direct motor drive which allows operation at 100% duty cycle. This assures efficiency and reliability. The fail-safe, fail-secure options of the K-2™ gate operator allows it to handle gates up to 650 lbs. in conformance with UL 325 and UL 991 Type I, III and IV.

the viking K-2™ slide gate operation

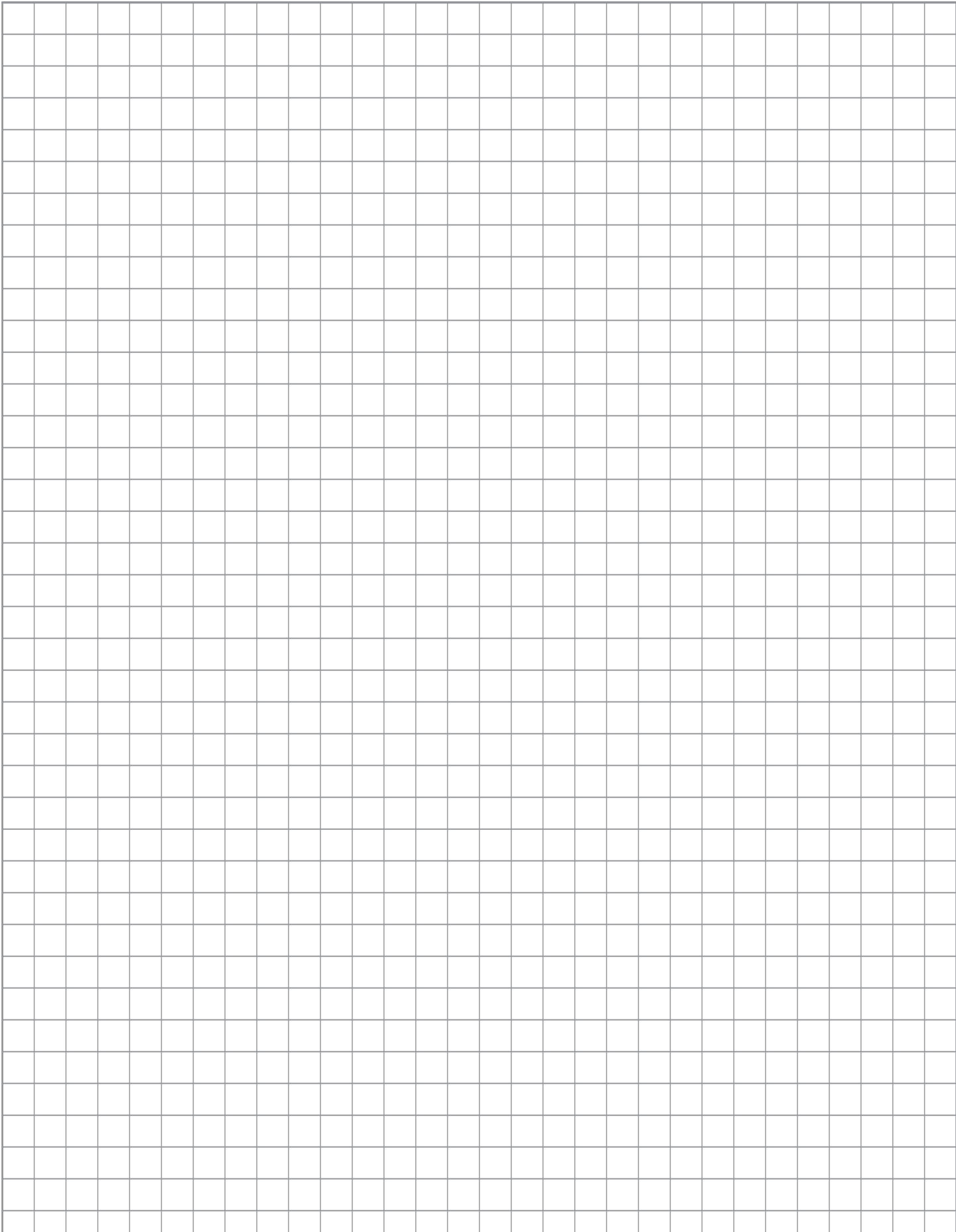

PARTS DIAGRAM

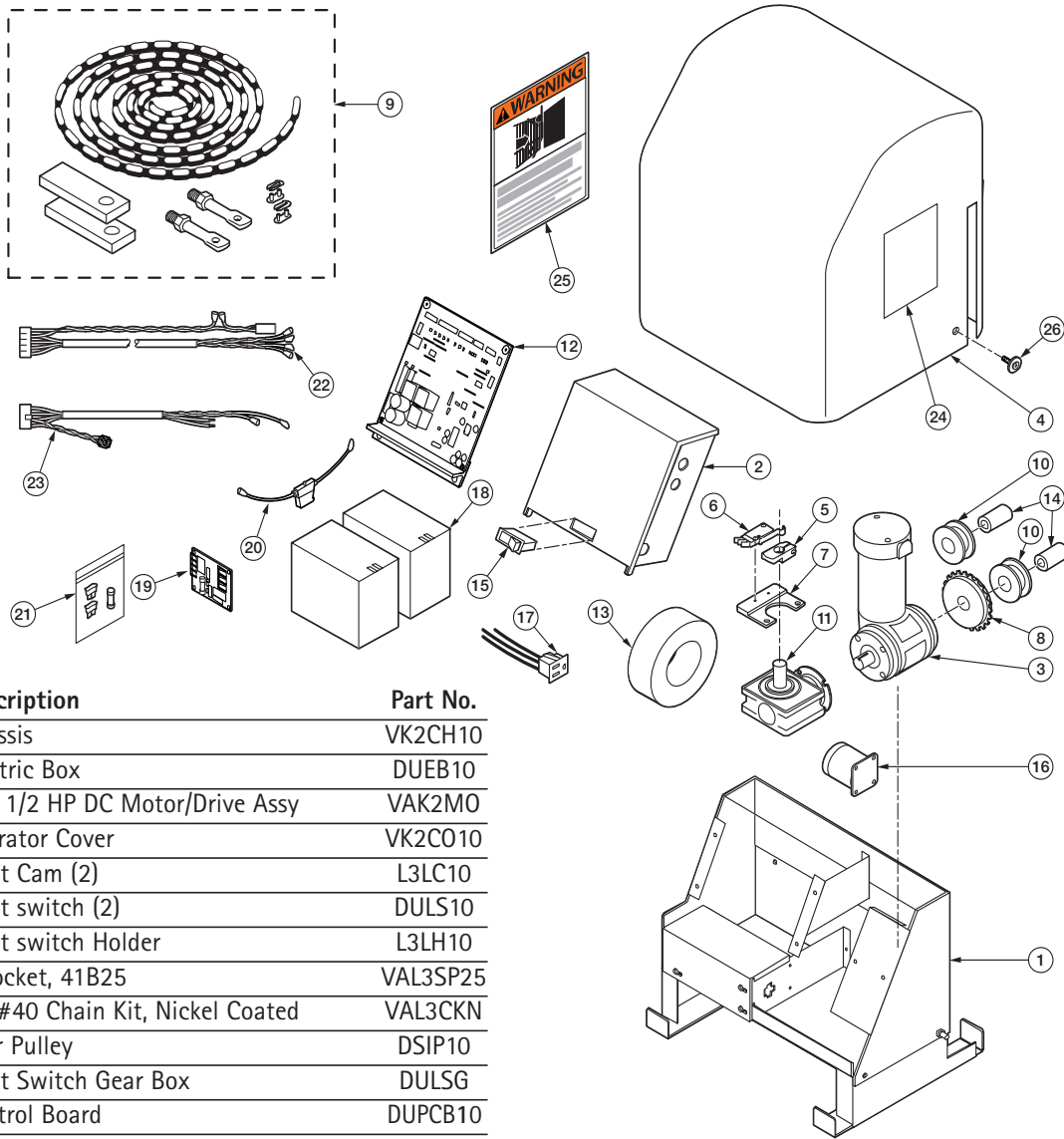

Item	Description	Part No.
1	Chassis	VK2CH10
2	Electric Box	DUEB10
3	24V 1/2 HP DC Motor/Drive Assy	VAK2MO
4	Operator Cover	VK2CO10
5	Limit Cam (2)	L3LC10
6	Limit switch (2)	DULS10
7	Limit switch Holder	L3LH10
8	Sprocket, 41B25	VAL3SP25
9	25' #40 Chain Kit, Nickel Coated	VAL3CKN
10	Idler Pulley	DSIP10
11	Limit Switch Gear Box	DULSG
12	Control Board	DUPCB10
13	Toroid Transformer, 10 amp	DUTT10
14	Idler Bushing	DSIB10
15	Reset Switch	DUMRS10
16	Alarm	DUAL10
17	Receptacle	DUOL120
18	Battery	DUBA12
19	EMI Board	DUEMI10
20	Battery Fuse Holder	VABFH
21	Fuse Kit	DUFUSKT
22	Limit Switch Harness	K2LSWH
23	Power Harness	DUPHC
24	Warning Sticker	DUWL
25	Warning Placard	DUWPA
26	Cover Release Nut	VASLCB

Overall Dimensions

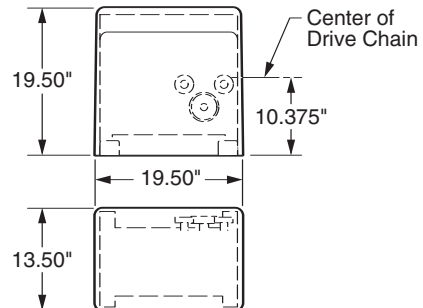

Weight

75 lb.

**WARNING - For Installation
By Qualified Personnel Only.**



TABLE OF CONTENTS

Parts Diagram/Parts List	i
Important Safety Information	
Important Safety Instructions	2
Important Installation Instructions	2-3
Maintenance/General Safety Precautions	4
Terminology	5
Photo Beam (non-contact sensor) Installation	6
Edge Sensor (contact sensor) Installation	7
Manual Release	7
Audible Alarm Reset Switch Installation	8
Warning Placard Installation	8
Important Installation Information	9
Specifications	9
Plans of Installation	10
Plan of Installation – Concrete Pads	11
Gate Operator Installation	
Step 1 through 3 – Operator Installation	12-13
Electrical Installation	
Step 4 – Electrical Installation (120/220 VAC)	14
Step 5 – Power Connections	15
Gate Operator Installation	
Limit Switch Connections	16
Step 6 – Limit Switch Setup	16-17
Special Features	
Fine Tune Limit Setting	18
Electrical Installation	
Master/Slave Connections	19
Vehicular Loop Detector Installation	
Loop Layout Diagrams	20
Installation Guidelines	21
Loop Rack Installation	22
Accessory Connections	
Open Commands; Safety Connections	23
Radio Receiver	24
Guard Station	25
Special Features	
Auto Open Feature	26
Intelligent Obstruction Sensor (Primary Entrapment Protection)	27
Fail Safe/Fail Secure Operation; Hold Open Timer	28
Optional VikingBlue™ Wireless Master/Slave Installation	29
Optional Solar Panel Installation	30-31
Optional Pipe Stand Installation	32
Optional Pedestal Stand	33
Optional VikingBlue™ Wireless Diagnostics Installation	34
Troubleshooting	35-37



IMPORTANT SAFETY INFORMATION

WARNING - Not following these instructions may cause severe injury or death to persons.

IMPORTANT SAFETY INSTRUCTIONS

WARNING – To reduce the risk of severe injury or death:

1. READ AND FOLLOW ALL INSTRUCTIONS.
2. Never let children operate or play with gate controls. Keep the remote control away from children.
3. Always keep people and objects away from the gate. **NO ONE SHOULD CROSS THE PATH OF THE MOVING GATE.**
4. Test the gate operator monthly. The gate **MUST** reverse on contact with a rigid object or when an object activates the non-contact sensors. After adjusting the force or the limit of travel, retest the gate operator. Failure to adjust and retest the gate operator properly can increase the risk of injury or death.
5. Use the manual release only when the gate is not moving.
6. **KEEP GATES PROPERLY MAINTAINED.** Read the owner's manual. Have a qualified service person make repairs to gate hardware.
7. The entrance is for vehicles only. Pedestrians must use separate entrance.
8. **Every gate operator installation MUST have secondary protection devices against entrapment, such as edge sensors and photo beams more in particularly in places where the risk of entrapment is more likely to occur.**
9. SAVE THESE INSTRUCTIONS.

IMPORTANT INSTALLATION INSTRUCTIONS

1. Install the gate operator only when:
 - a) The operator is appropriate for the construction of the gate and the usage Class of the gate (refer to page 5),
 - b) All openings of a horizontal slide gate are guarded or screened from the bottom of the gate to a minimum of 4 feet (1.22 m) above the ground to prevent a 2-1/4 inch (57.2 mm) diameter sphere from passing through the openings anywhere in the gate, and in that portion of the adjacent fence that the gate covers in the open position,
 - c) **ALL EXPOSED PINCH POINTS ARE ELIMINATED OR GUARDED, AND**
 - d) **GUARDING IS SUPPLIED FOR EXPOSED ROLLERS.**
2. The operator is intended for installation only on gates used for vehicles. Pedestrians must be supplied with a separate access opening. The pedestrian access opening shall be designed to promote pedestrian usage. Locate the gate such that persons will not come in contact with the vehicular gate during the entire path of travel of the vehicular gate.
3. The gate must be installed in a location so that enough clearance is supplied between the gate and adjacent structures when opening and closing to reduce the risk of entrapment. Swinging gates shall not open into public access areas.
4. The gate must be properly installed and work freely in both directions prior to the installation of the gate operator. Do not over-tighten the operator clutch or pressure relief valve to compensate for a damaged gate.
5. The gate operator controls must be placed so that the user has full view of the gate area when the gate is moving **AND AWAY FROM THE GATE PATH PERIMETER,**



IMPORTANT SAFETY INFORMATION

WARNING - Not following these instructions may cause severe injury or death to persons.

IMPORTANT INSTALLATION INSTRUCTIONS Continued

6. Controls intended for user activation must be located at least six feet (6') away from any moving part of the gate and where the user is prevented from reaching over, under, around or through the gate to operate the controls. Outdoor or easily accessible controls shall have a security feature to prevent unauthorized use.
7. The Stop and/or Reset button must be located in the line-of-sight of the gate. Activation of the reset control shall not cause the operator to start.
8. All warning signs and placards must be installed where visible in the area of the gate. A minimum of two placards shall be installed. A placard is to be installed in the area of each side of the gate and be visible to persons located on the side of the gate on which the placard is installed.
9. **For gate operators utilizing a non-contact sensor (Photo beam or like) in accordance with section 31.1.1 of the UL325 standard:**
 - a) **See instructions on the placement of non-contact sensors for each Type of application (refer to page 6),**
 - b) **Care shall be exercised to reduce the risk of nuisance tripping, such as when a vehicle, trips the sensor while the gate is still moving, and**
 - c) **One or more non-contact sensors shall be located where the risk of entrapment or obstruction exists, such as the perimeter reachable by a moving gate or barrier (refer to page 6).**
 - d) **Use only Omron E3K-R10K4 photoelectric eye to comply with UL325**
10. **For a gate operator utilizing a contact sensor (Edge sensor or like) in accordance with section 31.1.1 of the UL325 standard:**
 - a) **One or more contact sensors shall be located where the risk of entrapment or obstruction exists, such as at the leading edge, trailing edge, and post mounted both inside and outside of a vehicular horizontal slide gate (refer to page 7).**
 - b) **One or more contact sensors shall be located at the bottom edge of a vehicular vertical lift gate.**
 - c) **One or more contact sensors shall be located at the pinch point of a vehicular vertical pivot gate.**
 - d) **A hardwired contact sensor shall be located and its wiring arranged so that the communication between the sensor and the gate operator is not subjected to mechanical damage.**
 - e) **A wireless contact sensor such as one that transmits radio frequency (RF) signals to the gate operator for entrapment protection functions shall be located where the transmission of the signals are not obstructed or impeded by building structures, natural landscaping or similar obstruction. A wireless contact sensor shall function under the intended end-use conditions.**
 - f) **One or more contact sensors shall be located on the inside and outside leading edge of a swing gate. Additionally, if the bottom edge of a swing gate is greater than 6 inches (152 mm) above the ground at any point in its arc of travel, one or more contact sensors shall be located on the bottom edge (refer to page 7).**
 - g) **One or more contact sensors shall be located at the bottom edge of a vertical barrier (arm).**
 - h) **Use only Miller Edge Model MGR20 or MGS20 edge sensor to comply with UL325**



IMPORTANT SAFETY INFORMATION

WARNING - Not following these instructions may cause severe injury or death to persons.

MAINTENANCE

Remove the Power Harness from the Control Board (refer to page 14)

- Clean and lubricate the gate track wheels using the recommended lubricant.
- Inspect the track for any signs of cracking or separation.
- Check that all mounting hardware of the gate operator is properly tighten.
- Ensure that the gate moves freely.
- Check for corroded parts and replace if necessary.
- Check the battery for the following:
 - Battery connections must be free of corrosion.
 - Battery voltage must be 26 VDC (fully charged battery).

Reconnect the Power Harness for the Control Board (refer to page 14)

- Check and confirm the proper operation of all safety devices (photoelectric eye, edge sensors or like).
- Check and confirm the operation of all installed accessories.
- Check and confirm the operation of all special features such as the Intelligent Obstruction Sensor, Hold Open Timer (refer to page 23 to 28)
- Check and confirm the operation of the manual release (refer to page 7)
- Verify battery backup functionally by turning off the power source (120 VAC and 220 VAC). **DO NOT FORGET TO TURN ON THE POWER SOURCE AFTER VERIFICATION.**

GENERAL SAFETY PRECAUTIONS

The following precautions are an integral and essential part of the product and must be supplied to the user. Read them carefully as they contain important indications for the safe installation, use and maintenance.

- These instruction must be kept and forwarded to all possible future users of the system.
- This product must be used only for that which it has been expressly designed.
- Any other use is to be considered improper and therefore dangerous.
- The manufacturer cannot be held responsible for possible damage caused by improper, erroneous or unreasonable use.
- Avoid operating in the proximity of the hinges or moving mechanical parts.
- Do not enter the path of the moving gate while in motion.
- Do not obstruct the motion of the gate as this may cause a situation of danger.
- Do not allow children to play or stay within the the path of the moving gate.
- Keep remote control or any other control devices out of the reach of children, in order to avoid possible involuntary activation of the gate operator.
- In case of break down or malfunctioning of the product, disconnect from the main power source. Do not attempt to repair or intervene directly, contact only qualified personnel for repair.
- Failure to comply with the above may create a situation of danger.
- All cleaning, maintenance or repair work must be carried out by qualified personnel.
- In order to guarantee that the system works efficiently and correctly it is important to have the manufacturer's instructions on maintenance of the gate and operator carried out by qualified personnel.
- In particular, regular checks are recommended in order to verify that the safety devices are operating correctly.

All installation, maintenance and repair work must be documented and made available to the user.

Installer:

Signature _____

Date _____

Contact: _____



IMPORTANT SAFETY INFORMATION

CAUTION: To Reduce the Risk of Fire or Injury to Persons

- a) Use only the following type and size of battery(ies): Yuasa NP7-12
- b) Do not dispose of the battery(ies) in fire. The cells may explode. Check with local codes for possible disposal instructions.
- c) Do not open or mutilate the battery(ies). Released electrolyte is corrosive and may cause damage to the eyes or skin. It may be toxic if swallowed.
- d) Exercise care in handling batteries in order not to short the battery with conducting materials such as rings, bracelets and keys.
- e) Change the battery(ies) provided with or identified for use with this product only in accordance with the instructions and limitations specified in this manual.
- f) Observe proper polarity orientation between the battery(ies) and charging circuit.
- g) Do not mix batteries of different sizes or from different manufacturers in this product (applies to products employing more than one user replaceable secondary battery).
- h) A battery-operated product employing a secondary battery supply intended to be charged within the product shall contain specific instructions concerning the proper method of charging.

UL325 Gate Operator Classification

GLOSSARY

RESIDENTIAL VEHICULAR GATE OPERATOR

CLASS I – A vehicular gate operator (or system) intended for use in a home of one-to four single family dwelling, or a garage or parking area associated therewith.

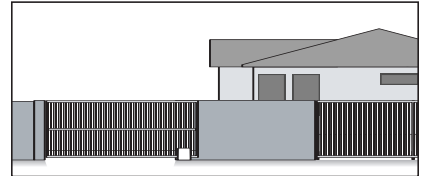

COMMERCIAL/GENERAL ACCESS VEHICULAR GATE OPERATOR

CLASS II – A vehicular gate operator (or system) intended for use in a commercial location or building such as a multi-family housing unit (five or more single family units), hotel, garages, retail store, or other building servicing the general public.

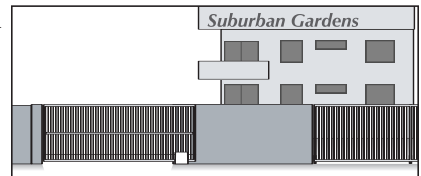

INDUSTRIAL/LIMITED ACCESS VEHICULAR GATE OPERATOR

CLASS III – A vehicular gate operator (or system) intended for use in an industrial location or building such as a factory or loading dock area or other locations not intended to service the general public.

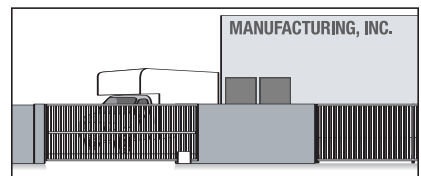

RESTRICTED ACCESS VEHICULAR GATE OPERATOR

CLASS IV – A vehicular gate operator (or system) intended for use in a guarded industrial location or building such as an airport security area or other restricted access locations not servicing the general public, in which unauthorized access is prevented via supervision by security personnel.

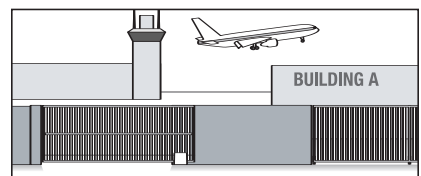

Install the gate operator only when:

The operator is appropriate for the construction of the gate and the Usage Class of the gate.



IMPORTANT SAFETY INFORMATION

WARNING - Not following these instructions may cause severe injury or death to persons.

NOTE - This type of installation DOES NOT reverse the gate all the way back to its limits when the photo-beam is obstructed. This installation is only to protect against entrapment and to comply with UL325.

Photo Beam (non-contact sensor) Installation

Secondary Entrapment Protection

Photo beams or like must be installed to reduce the risk of entrapment.

Use only Omron E3K-R10K4 photoelectric eye to comply with UL325

Make the electrical connections of the photoelectric sensor as described here in this page.

Care shall be exercised to reduce the risk of nuisance tripping, such as when a vehicle, trips the sensor while the gate is still moving, and

One or more non-contact sensors shall be located where the risk of entrapment or obstruction exists, such as the perimeter reachable by a moving gate or barrier.

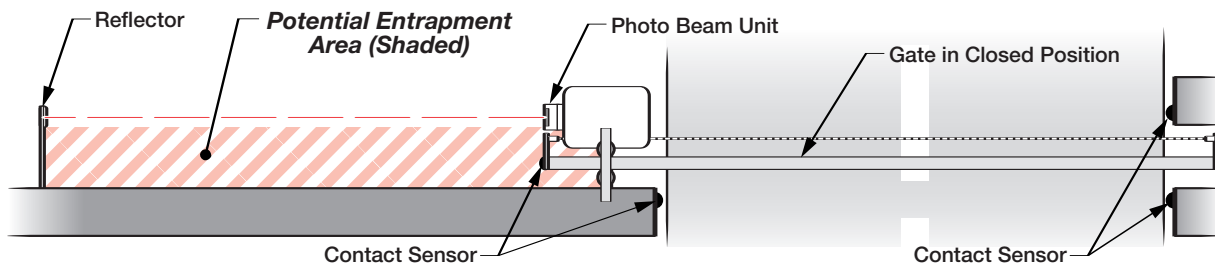
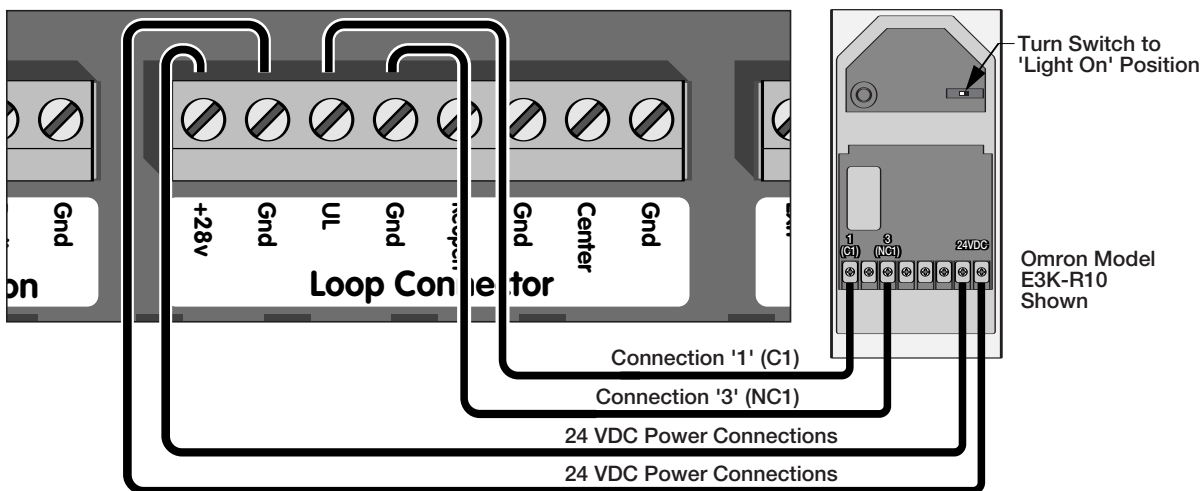

One or more non-contact sensors shall be located where the risk of entrapment or obstruction exists, such as the perimeter reachable by a moving gate or barrier.

Consult the installation manual for the UL325 device (photo beam or like) for detail information about the usage, installation and maintenance



IMPORTANT SAFETY INFORMATION

WARNING - Not following these instructions may cause severe injury or death to persons.

Edge Sensor (contact sensor) Installation

Secondary Entrapment Protection

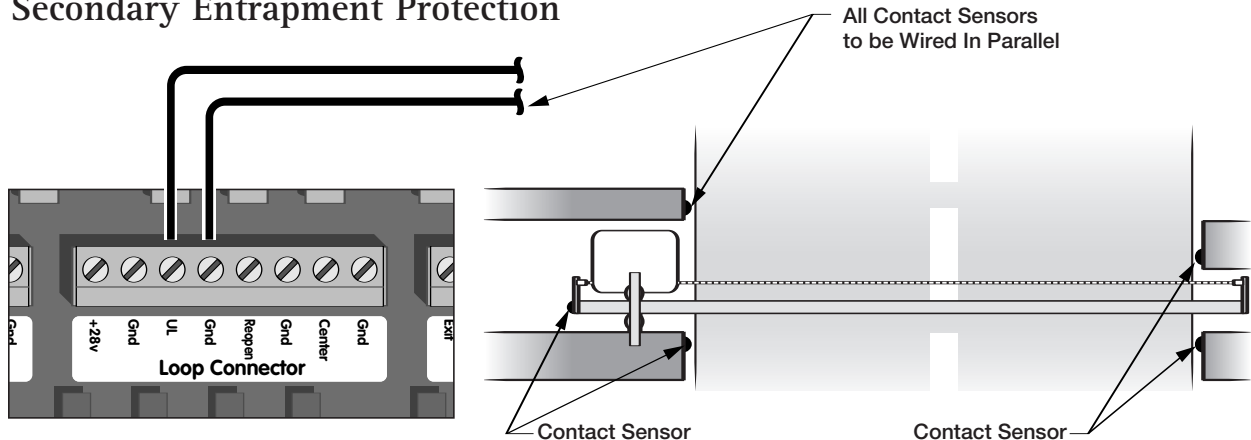

Edge sensor or like must be installed to reduce the risk of entrapment.

Use only Miller Edge 3-sided activation type MGR20 or MGS20 to comply with UL325. One or more contact sensors shall be located on the inside and outside leading edge of a swing gate. Additionally, if the bottom edge of a swing gate is greater than 6 inches (152 mm) above the ground at any point in its arc of travel, one or more contact sensors shall be located on the bottom edge.

1. A hardwired contact sensor shall be located and its wiring arranged so that the communication between the sensor and the gate operator is not subjected to mechanical damage.
2. A wireless contact sensor such as one that transmits radio frequency (RF) signals to the gate operator for entrapment protection functions shall be located where the transmission of the signals are not obstructed or impeded by building structures, natural landscaping or similar obstruction. A wireless contact sensor shall function under the intended end-use conditions.

Manual Release

When manual operation is required:

Remove the cover, locate the Reset Switch and turn it to the "OFF" position. The gate can now move manually.

Turn the switch to the "RESET" position to resume normal operation.

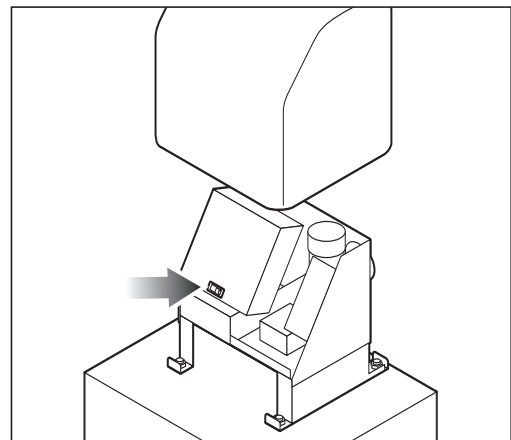

IMPORTANT SAFETY INFORMATION

WARNING - Not following these instructions may cause severe injury or death to persons.

Audible Alarm Reset Switch Installation

Manual Reset for the Audible Alarm

UL325 standard requires an audible alarm to go off after two consecutive events detected by the primary entrapment protection of the gate operator (obstruction sensor).

The audible alarm will continue to sound for 5 minutes or until a stop command gets actuated.

The Stop command can be actuated in two different forms

1. Using the Built in Stop switch on the Control Box or
2. Using an External Stop button within the sight of the gate, away from moving parts of the gate and out of reach of children.
3. Controls intended for user activation must be located at least six feet (6') away from any moving part of the gate and where the user is prevented from reaching over, under, around or through the gate to operate the controls. Outdoor or easily accessible controls shall have a security feature to prevent unauthorized use.
4. The Stop and/or Reset button must be located in the line-of-sight of the gate. Activation of the reset control shall not cause the operator to start.

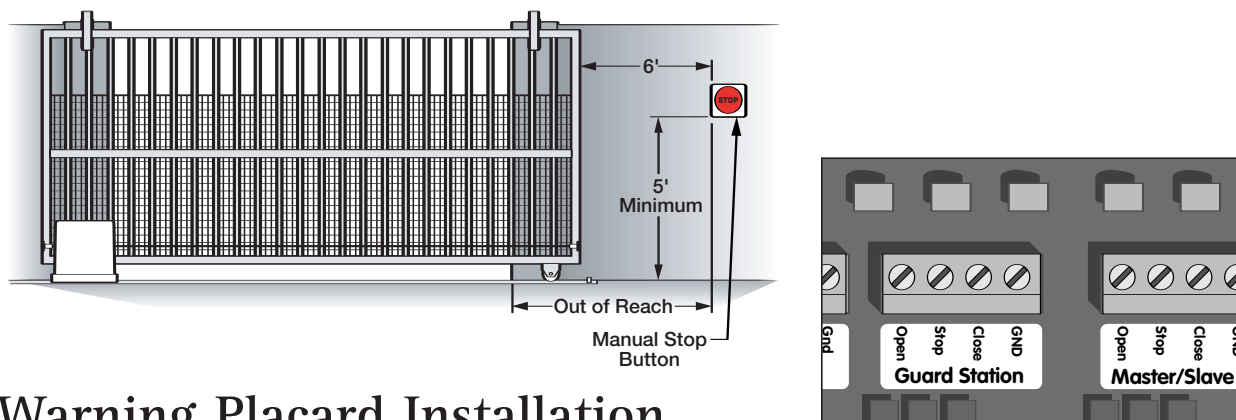

Warning Placard Installation

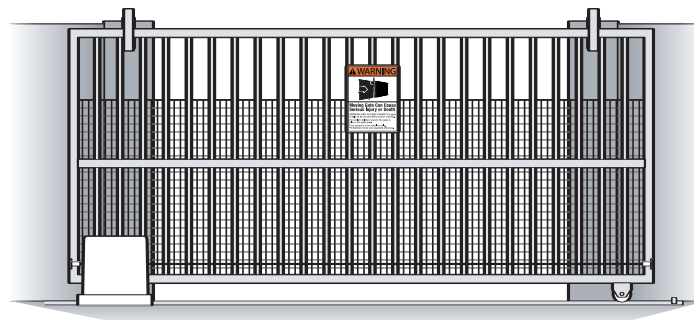

All Warning Signs and Placards must be installed where visible in the area of the gate. A minimum of two placards shall be installed. A placard is to be installed in the area of each side of the gate and be visible.



IMPORTANT INSTALLATION INFORMATION

**CAUTION - FOR USE WITH GATES OF A MAXIMUM OF 27 FT IN LENGTH AND 650 LBS. IN WEIGHT.
WARNING - TO REDUCE THE RISK OF SEVERE INJURY OR DEATH TO PERSONS:**

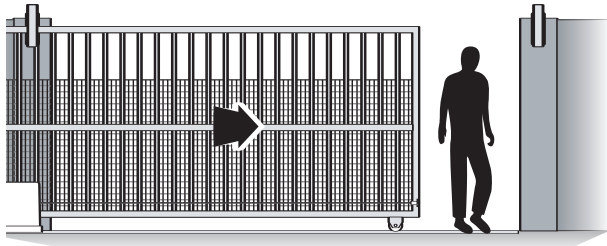

Do not allow pedestrian use of this gate!

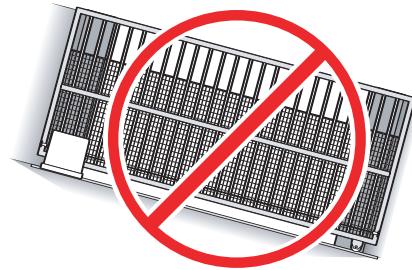

Do NOT Install the gate operator to lift gates

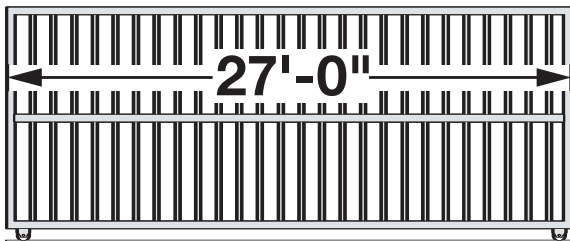

27' maximum gate length

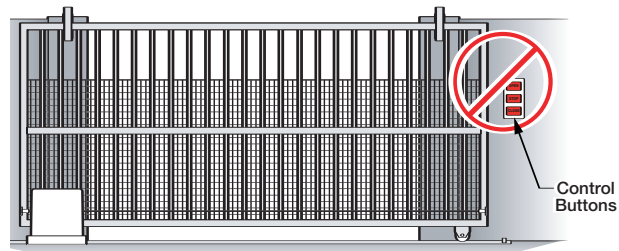

Locate Control Buttons:

1. Within sight of the gate,
2. At a minimum height of 5 feet so small children are not able to reach it, and
3. Away from the gate opening so that someone cannot operate the controls while in the path of the gate, and
3. Away from all moving parts of the gate.

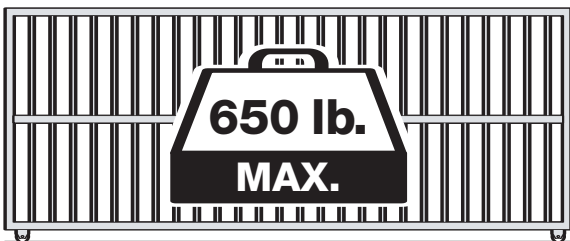

650 pounds maximum gate weight

Specifications

Maximum Gate Length:	27 feet
Maximum Gate Weight:	650 lbs.
Power Requirements:	120 VAC Single Phase at 2 Amps Or 220 VAC Single Phase at 1 Amp
Operating Temperature:	-20°C (-4°F) to 70°C (158°F)



PLANS OF INSTALLATION

All openings of a horizontal slide gate are guarded or screened from the bottom of the gate to a minimum of 4 feet (1.22 m) above the ground to prevent a 2-1/2 inch (57.2 mm) diameter sphere from passing through the openings anywhere in the gate, and in that portion of the adjacent fence that the gate covers in the open position.

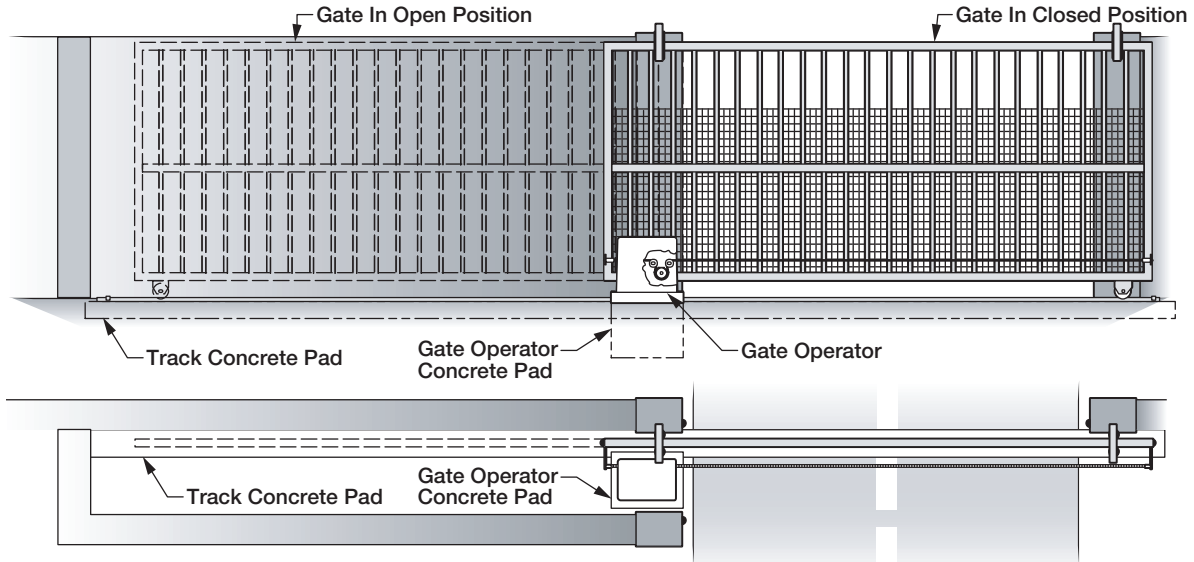
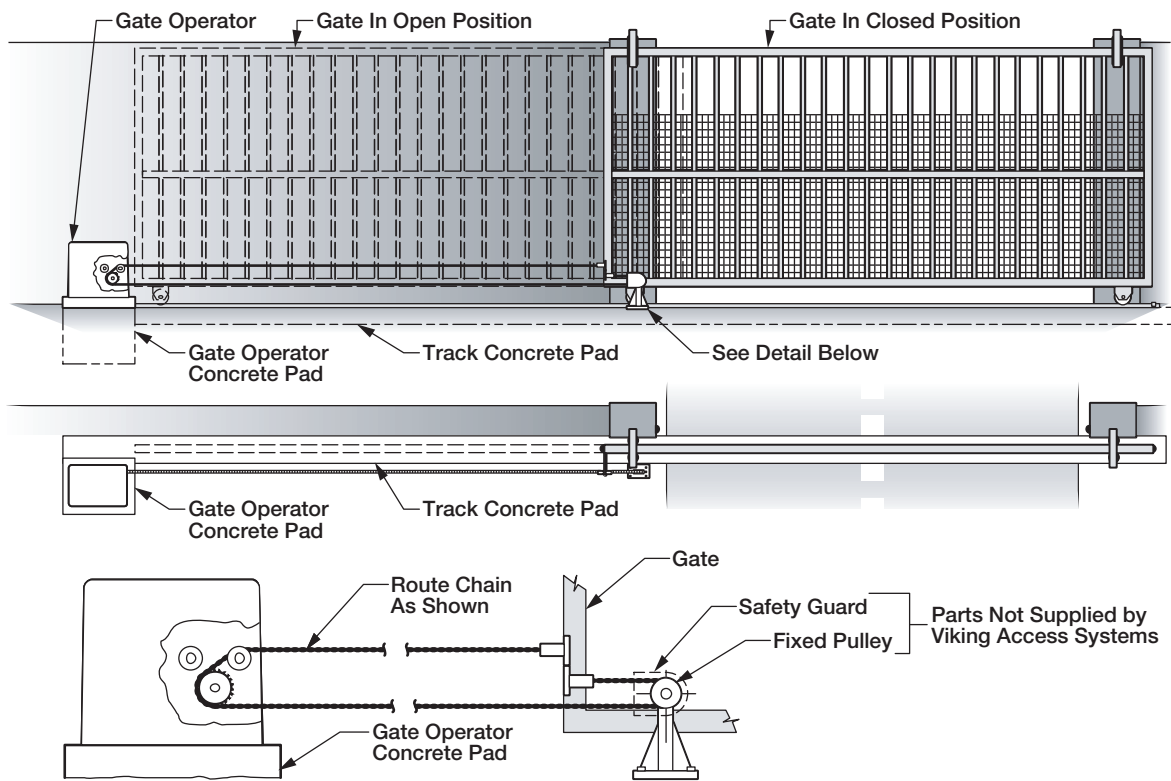

Figure A
Plan of Front Installation



Detail of Rear Install Chain Route

Figure B
Plan of Rear Installation



PLAN OF INSTALLATION – CONCRETE PADS

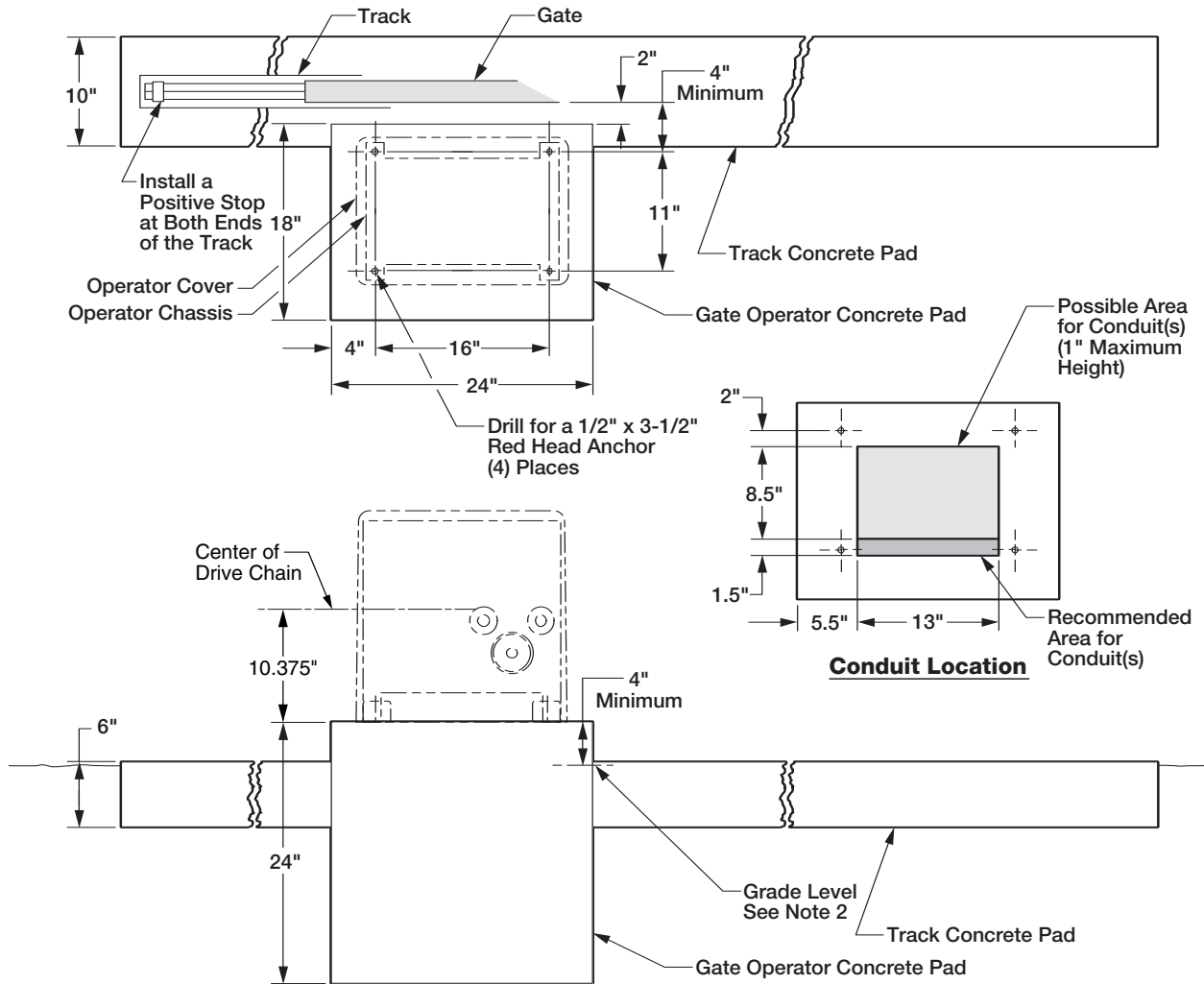

1. Follow the local building code to determine the required depth of the concrete pad.
2. Pad measurements recommended by Viking Access Systems are at least 24" long, 18" wide and 24" deep to ensure the stable operation of the operator, and a minimum of 4" above level grade to avoid any flooding of the machinery.
3. The path of the track must be 10" wide and at least 6" deep to support the weight of the gate. Please consult the local building code for verification and further details.
4. Provide a sufficient number of conduit pathways for all low power accessories such as loop detector leads, maglock, non-contact sensors, contact sensors, safety and other commands. Also provide conduit for the power supply (either 110 or 220 VAC). Extend the conduit the recommended height of 1" above the level of the concrete pad. Install all conduit in the shaded area shown above.



GATE OPERATOR INSTALLATION

Note: Before starting the installation procedure;

- Open and close the gate manually, making sure there is sufficient space between the gate and adjacent walls.
- Check that the wheels are turning freely on the track and there are no restrictions while pushing the gate to the open and closed positions.
- Confirm that there is adequate spacing for the guide rollers and that there are no restrictions throughout the travel of the gate.

STEP 1

Before anchoring the chassis to the concrete pad, make sure the gate and operator are **LEVEL** and **PARALLEL**. Minimum distance between the operator and gate is 3”.

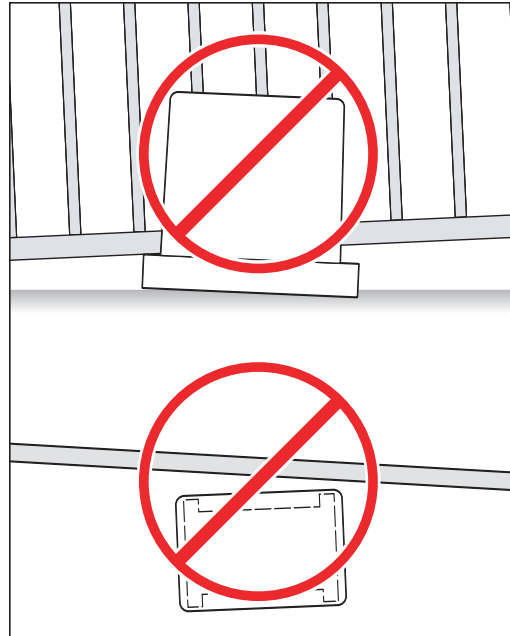

STEP 2

Attach the operator to the concrete pad using Red Head 1/2” x 3-1/2” Anchors. Follow the manufacturers instructions for proper installation. Refer to page 11 for hole center dimensions.

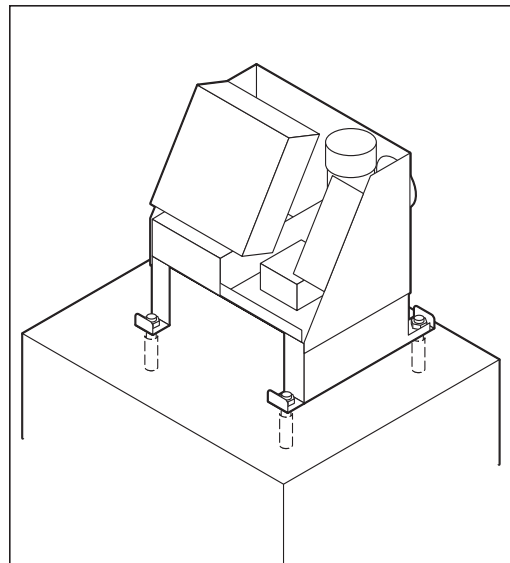

GATE OPERATOR INSTALLATION

Step 3

Chain Installation: Before welding the provided chain brackets, make sure the chain will be in a straight line with, and at the same height as, the chain leaving the gate operator rollers.

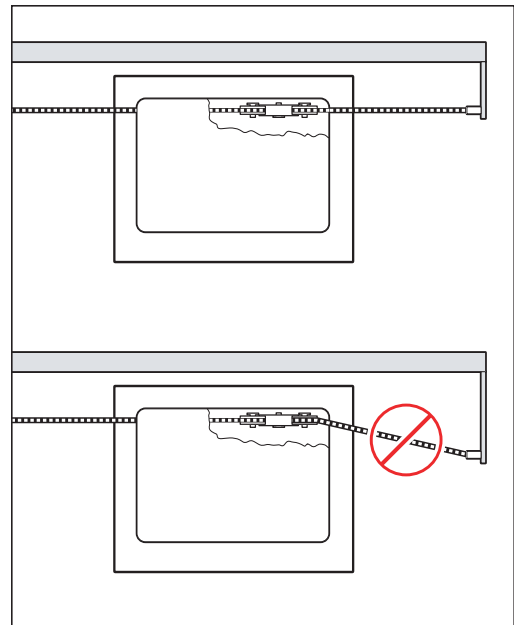
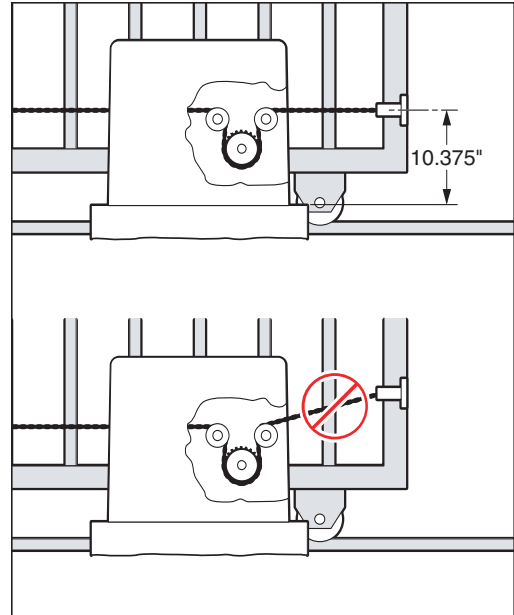

ELECTRICAL INSTALLATION

Caution – Do not connect the power harness to the board until the installation is ready for verification.

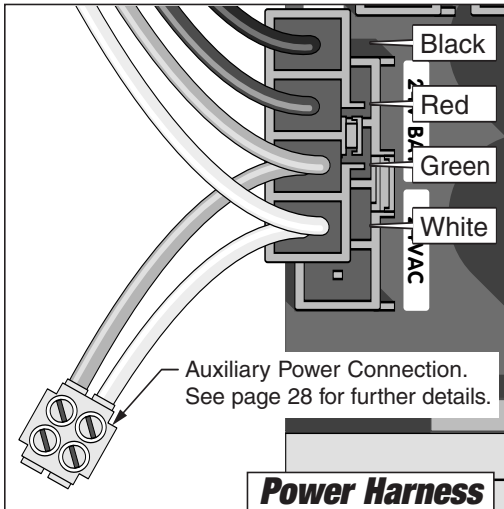

STEP 4

The Gate Operator requires a single phase AC line to operate the gate and charge the batteries.

- Turn off the main switch or breaker for the power line being used.
- Move the selector switch on the Incoming Voltage Selector to the proper position (115 for 110 to 120VAC, 230 for 200 to 240VAC).
- Connect the incoming power wires to the terminals as shown in the illustration.
- Turn on the main switch or breaker once the installation is ready for final adjustments.
- To verify that there is AC power to the system, check that the 'Charger' LED on the Control Board is on.

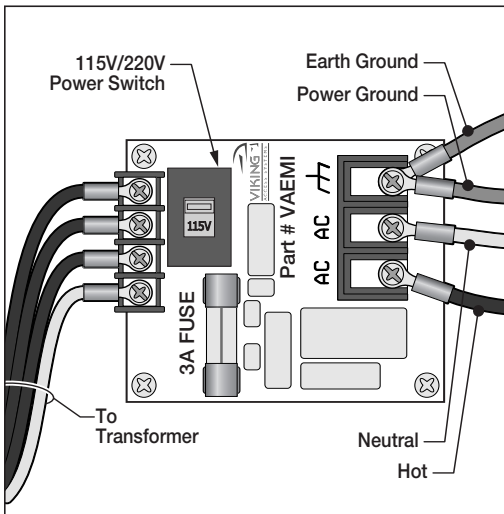

Tips for proper ground installation

A good ground in a gate operator installation will minimize or prevent damage to the operator caused by natural events such as lightning strikes.

The following will provide a guideline for proper grounding:

- Use a ground rod to provide a ground reference.
- Consult your city code and be aware of under-ground services in the site of the gate operator to prevent inconveniences.
- Use always a single bonding point for grounding.
- All ground wires must be as short and as thick as possible.
- Prevent unnecessary turns or loops in all ground wires.

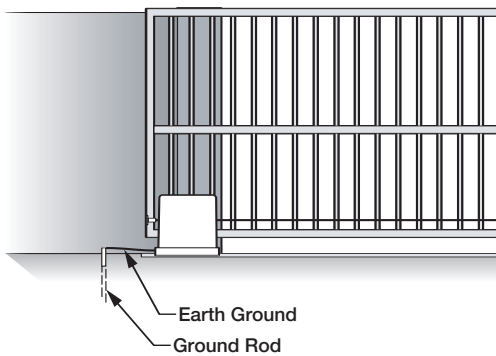

ELECTRICAL INSTALLATION

Power Connections

STEP 5

Connect the wire harness to the “OPEN RIGHT” connector if the gate opens to the right. Connect the wire harness to the “OPEN LEFT” connector if the gate opens to the left.

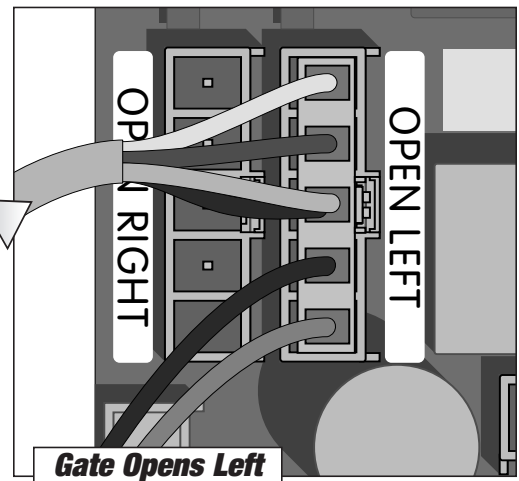
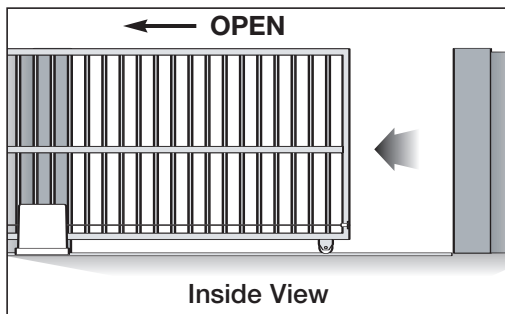
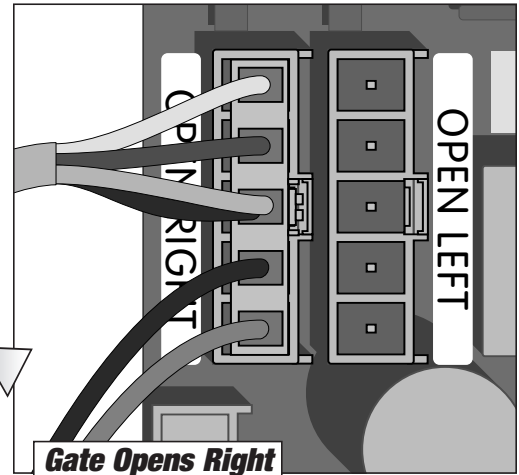
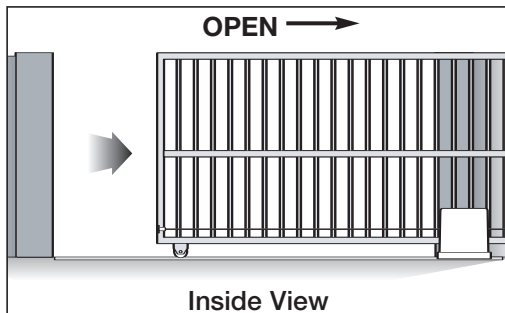

Limit Switch Connections

The Limit Switches are pre-wired. Should the wires become disconnected, use this diagram to reconnect them.

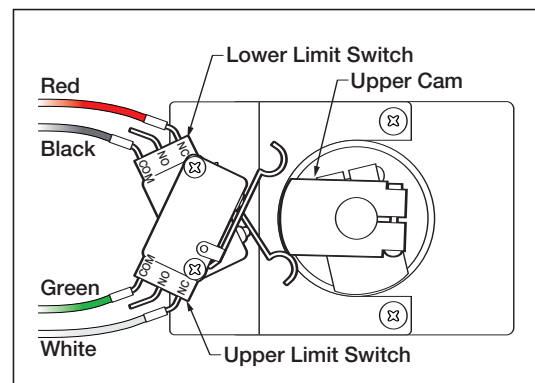

LIMIT SWITCH SET-UP

Note: *Open and close the gate without interruption every time you change the adjustment.*

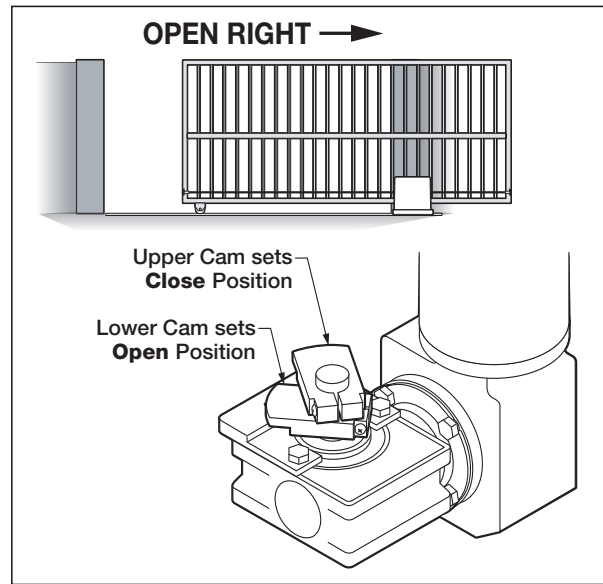
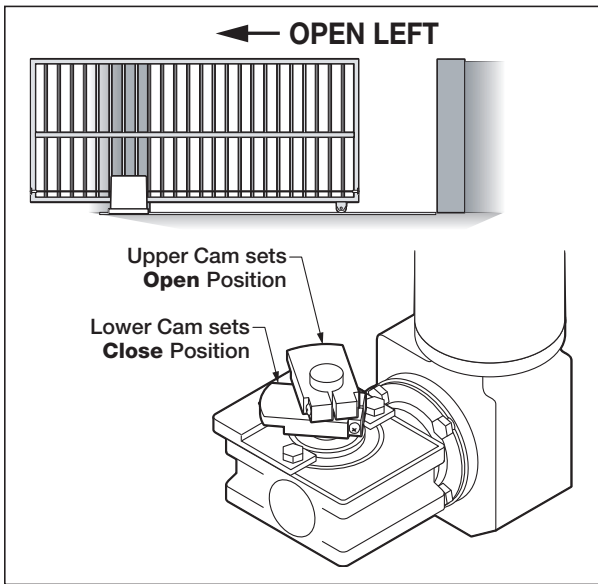

STEP 1

Set the Fine Tune Limit Pot to zero on the Control Board.

Trim Pot Location

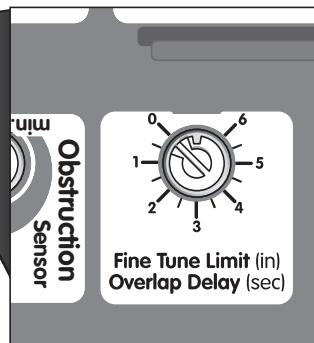
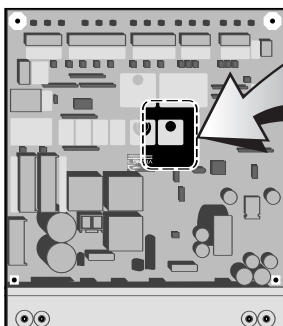

This 'Trim Pot' can be used to FINE ADJUST the closing position of the gate with a high degree of accuracy (up to 1/16"). The number on the Trim Pot dial sets the number of inches the gate travels after initial set-up.

STEP 2

Open the gate to the desired open position. Loosen and rotate the 'Open' Cam until the Limit Switch "clicks". Tighten the cam.

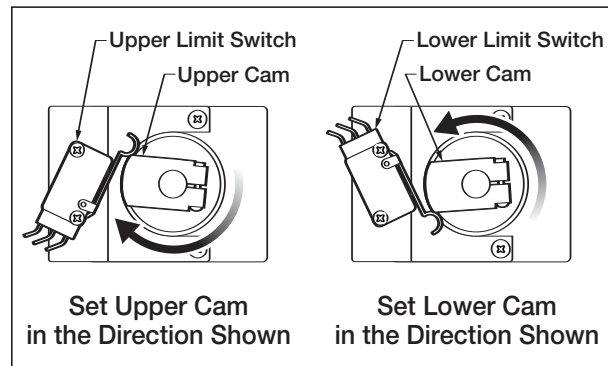

STEP 3

Close the gate to within 6" of desired closed position. Loosen and rotate the cam until the Limit Switch "clicks". Tighten the cam.

LIMIT SWITCH SET-UP

STEP 4

Press both limit switches at the same time to initiate the set-up (the open and close LEDs will blink on the Control Board).

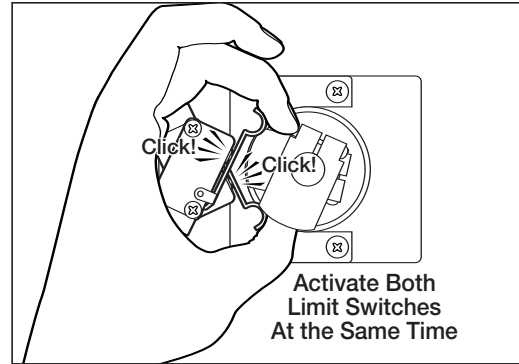

STEP 5

Open and close the gate from limit to limit without interruption for two complete cycles.

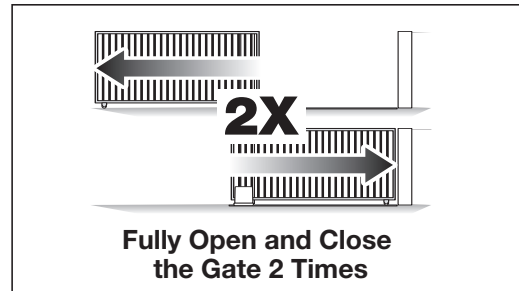

STEP 6

Use the Fine Tune Limit Pot to perform minor adjustments to the closed position.

6"

Initial Setting

Fine Tune Limit (in)
Overlap Delay (sec)

2-1/2"

First Adjustment

Fine Tune Limit (in)
Overlap Delay (sec)

1/2"

Second Adjustment

Fine Tune Limit (in)
Overlap Delay (sec)

Fully Open and Close the Gate After Every Adjustment



SPECIAL FEATURES

Fine Tune Limit Setting

The Fine Tune Limit Pot is used to closely set the final stop of the gate travel. The position can be set to the nearest 1/2" via the markings for the Trim Pot. See page 16-17 for setup procedure.

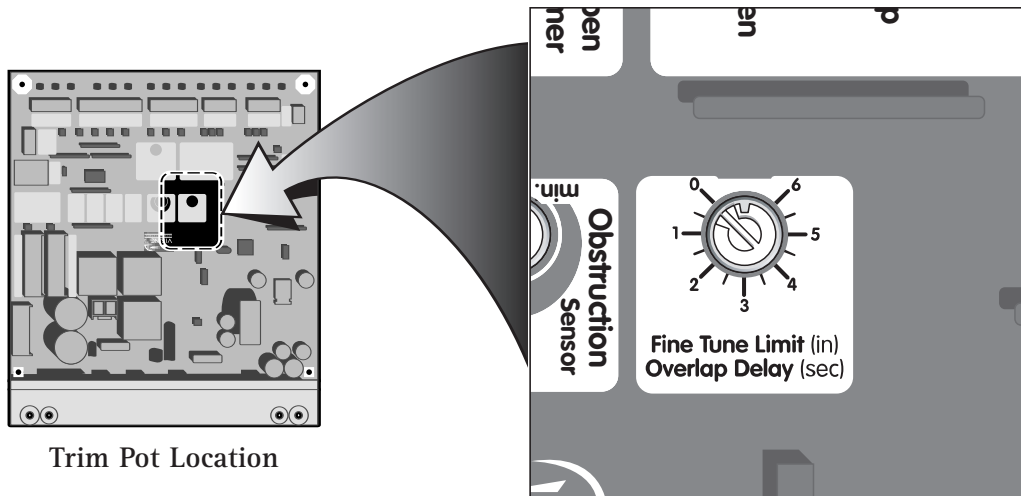

ELECTRICAL INSTALLATION – MASTER/SLAVE

Master/Slave Connections

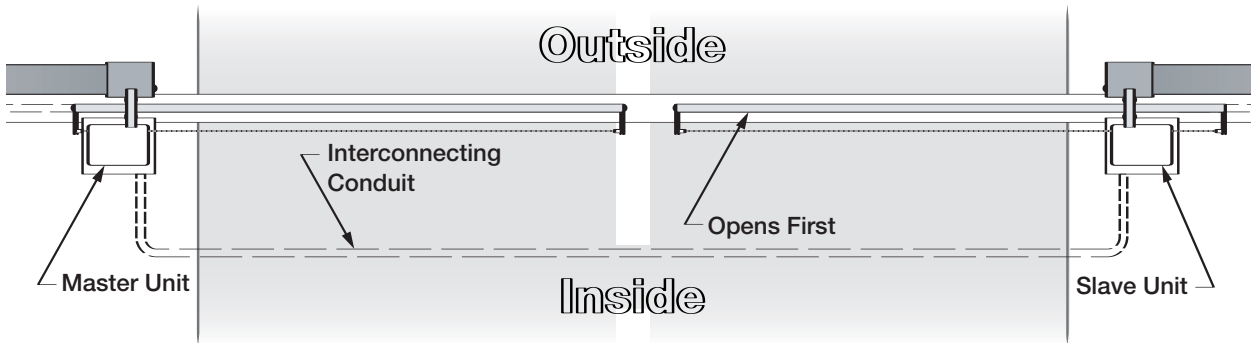

Caution – Do not run Master/Slave communication cable in the same conduit as the power supply (120-220V) cable.

Use 18 AWG stranded wire with foil overshield and drain wire or better.

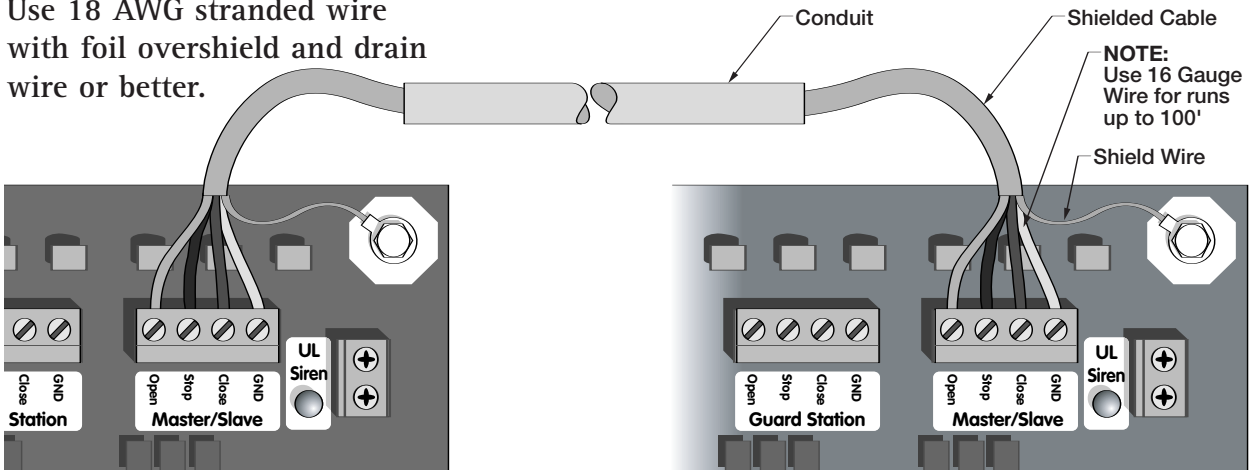

The control board provides a connector for master/slave connectivity. This connector will allow synchronized operation with a second gate operator.

Wire the operators as shown above and interconnect the two operators as follows:

Master Board	Slave Board	Purpose
GND	GND	Reference
Close	Close	Close Command
Stop	Stop	Stop Command
Open	Open	Open Command
Shield (to Earth)	Shield (to Earth)	

Note: It is recommended to connect all external devices and set timer and overlap delay control on the master unit. Ensure Slave Control Board has timer set to 'OFF' to allow the Master to control the timer.



VEHICULAR LOOP DETECTOR INSTALLATION

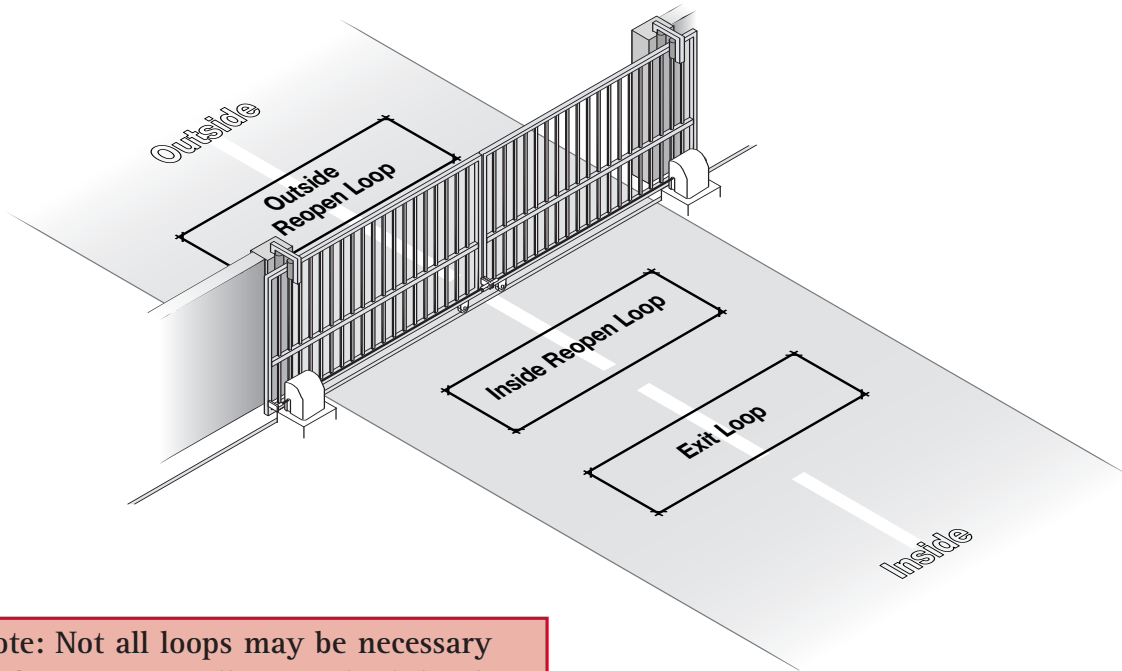

Note: Not all loops may be necessary for every installation. Check local regulations and accepted best-practice design requirements.

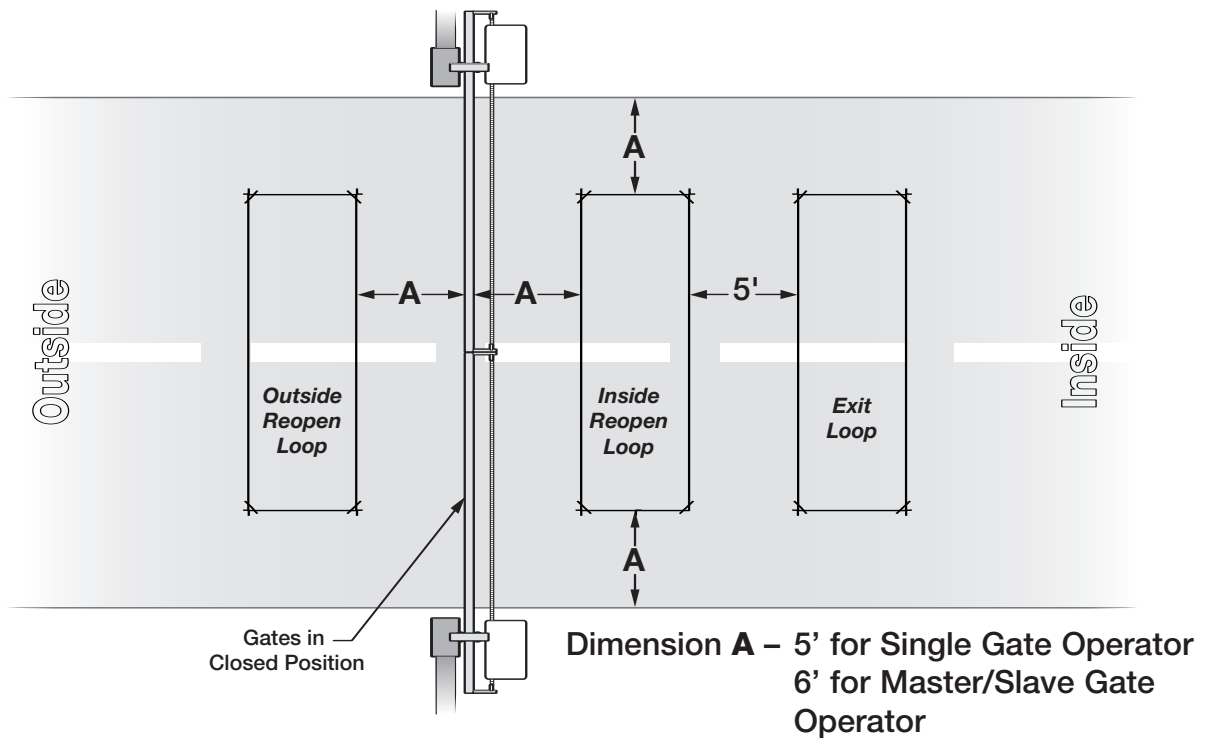

VEHICULAR LOOP DETECTOR INSTALLATION

WARNING – Consult the installation instructions from the loop detector manufacturer. The following statements are provided as a guide but different requirements may be required by the vehicular loop detector manufacturer.

Guidelines for Vehicular Loop Detector Installation

1. Prevent sharp corners in the geometry of the loop sensor.
2. Install the appropriate number of turns for your loop geometry based on the loop perimeter. Use Table C (below) as a guide.
3. Use XLP (cross-linked-polyethylene) type of wire. This wire reduces the effects of moisture and other environmental events in altering the functionality of the vehicular loop detector.
4. Twist the lead wire at least 6 turns per foot.
5. Use BACKER-ROD to minimize damage to the loop detector wire prior to using the sealant.
6. Place the loop detector wire and adjust the sensitivity of the vehicular loop detector unit in a way to minimize the effects of the gate over the loop detector wire.

IMPORTANT – Some of the following parameters may affect the proper functionality of the vehicular loop detector (consult the installation manual and the manufacturer of the vehicular loop detector).

- Gate size,
- Number of turns in the loop sensor wire;
- Distance from the loop sensor wire to the gate either at the open or close position.

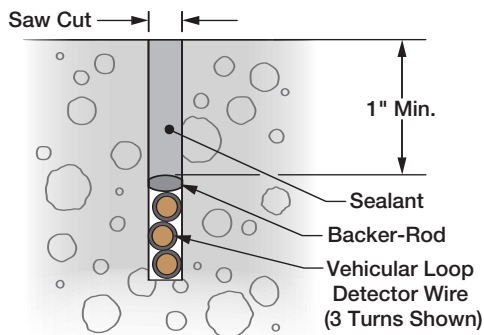
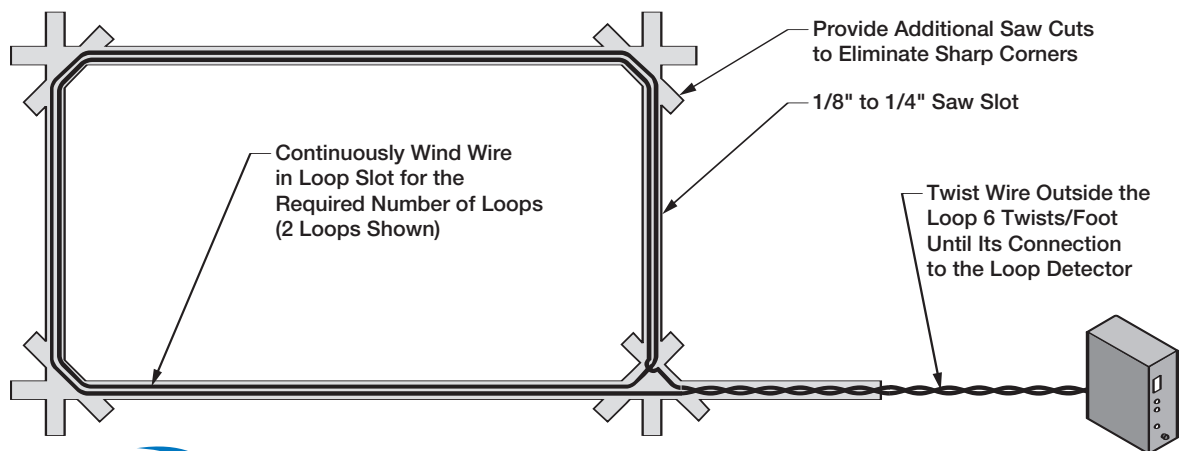

Table C – Recommended Number of Turns

Perimeter in Feet	Number of Turns
10	5
20	4
30-40	3
50-100	2



LOOP RACK INSTALLATION

Looprack – Viking Part # VA LR

Looprack Wiring Harness – Viking Part # VA LRH

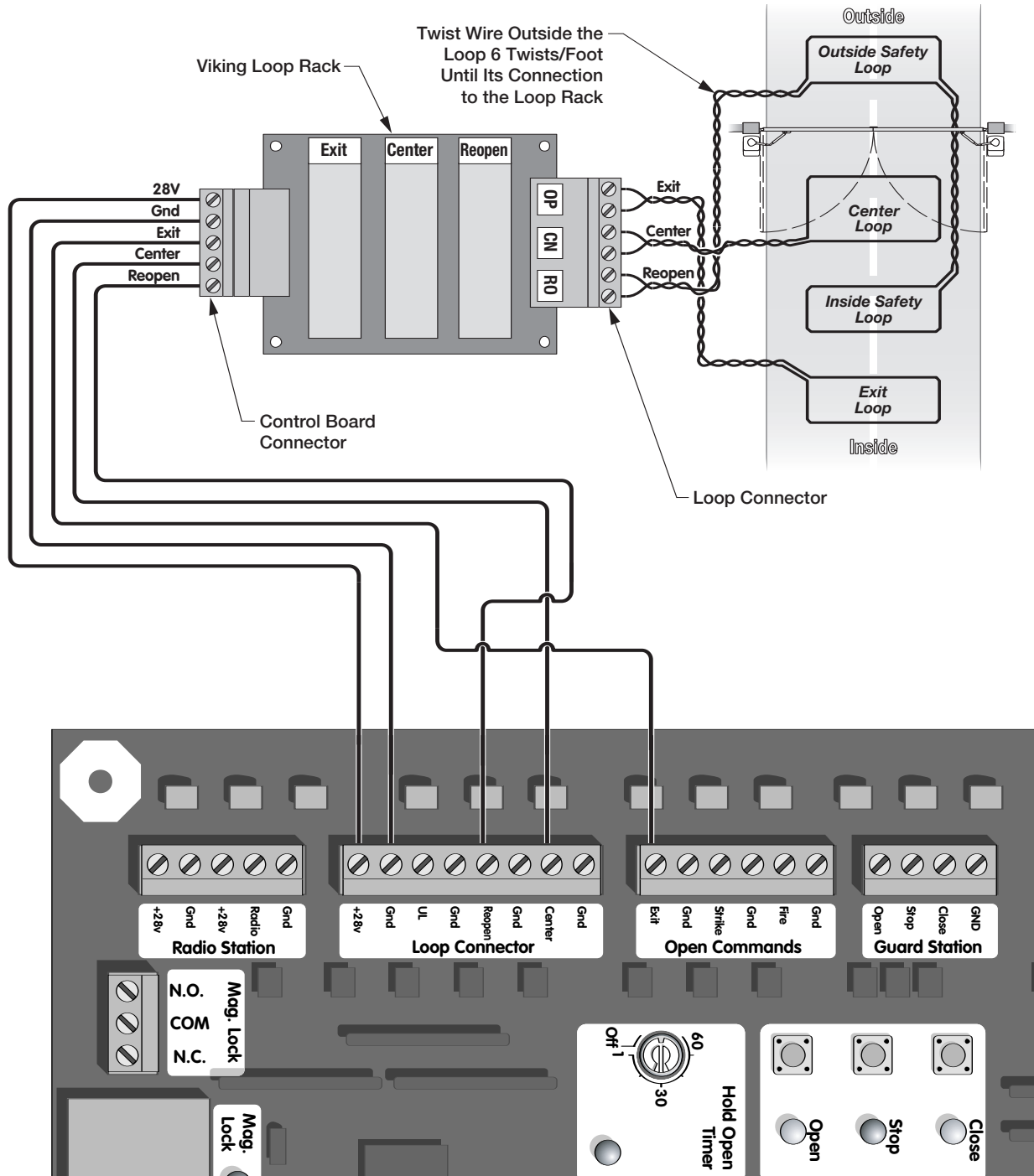

ACCESSORY CONNECTIONS

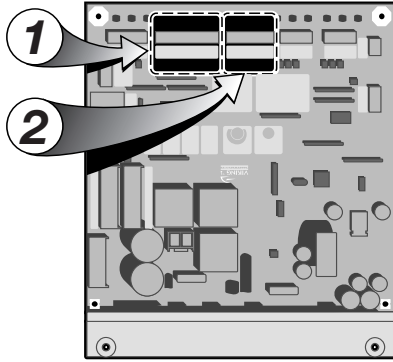

Connection Locations

Vehicle loop detectors must be installed to decrease the possibility of vehicle entrapment on the gate (see page 20).

The SECONDARY ENTRAPMENT PROTECTION like the edge sensor and the photoelectric beam MUST BE PART OF EVERY SINGLE INSTALLATION to prevent pedestrian or animal entrapment (see pages 6 and 7).

The edge sensor and/or the photoelectric beam must be UL325 compliant devices.

Safety Connections

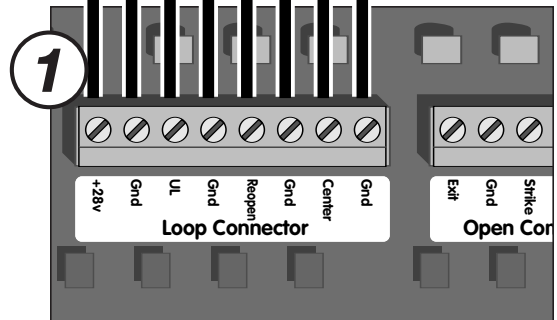
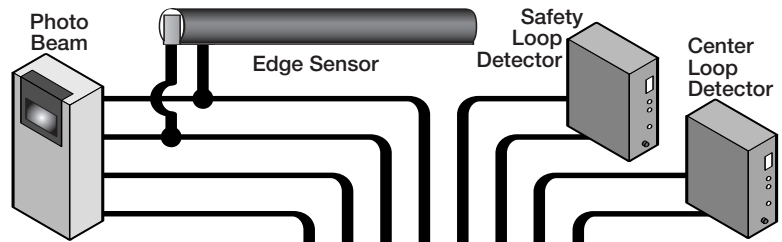

Open Commands

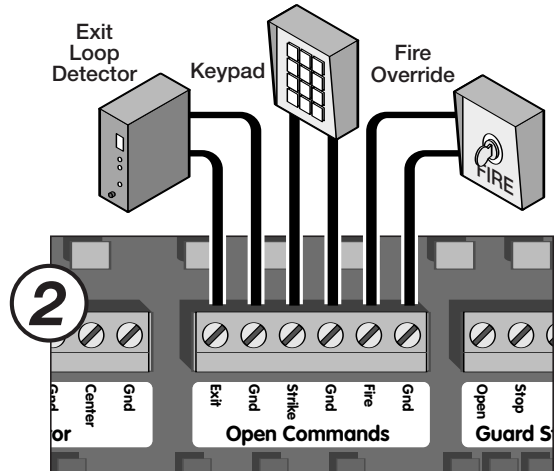

Reopen Photo Beam

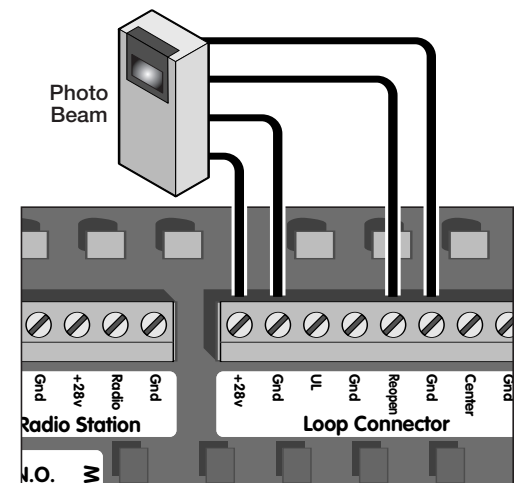

As an alternative to the Outside Reopen Loop, a photo beam unit can be used as shown.

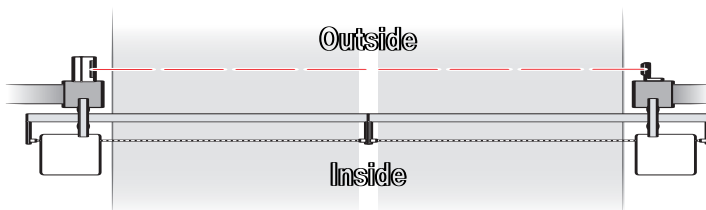

ACCESSORY CONNECTIONS

Radio Receiver

When connecting the Radio Receiver carefully verify the proper connections.

The maximum voltage that the control board provides for external accessories is the maximum voltage of the battery, which is about 28 volts.

In the event of an electrical short the board will protect itself by shutting down and will remain shut down until the short is corrected.

The control board provides two modes of operation that a radio receiver can control the gate:

Open-Stop-Close

1. By having the radio receiver connected as illustrated and with the Hold Open Timer OFF (see page 28):

Every command of the radio transmitter will control the gate as follow:

- a) First command opens the gate,
- b) Second command stops the gate and
- c) Third command closes the gate
- d) Any subsequent commands will continue in the same order to control the gate.

This type of configuration is not recommended for a commercial installations.

Open Only

2. By having the radio receiver connected as illustrated and with the Hold Open Timer ON (see page 28):

Each command of the radio transmitter is ALWAYS AN OPEN COMMAND to the gate.

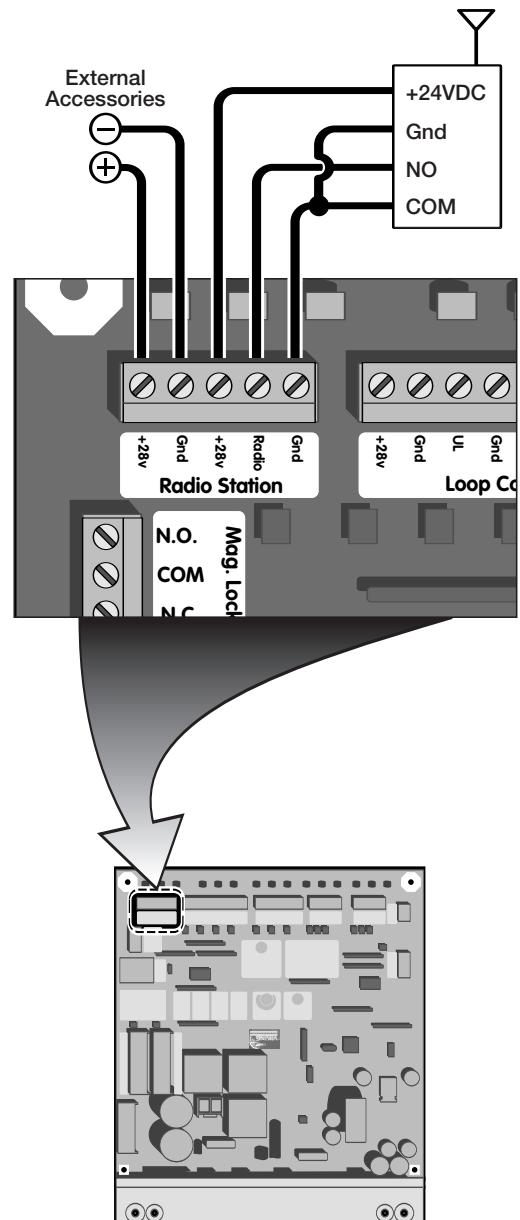

ACCESSORY CONNECTIONS

Note: All controls are normally open.

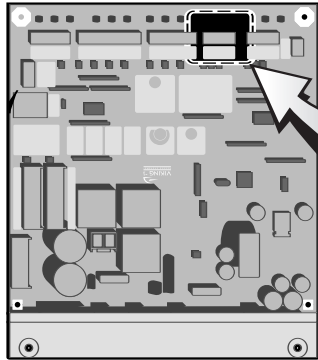

Connection Locations

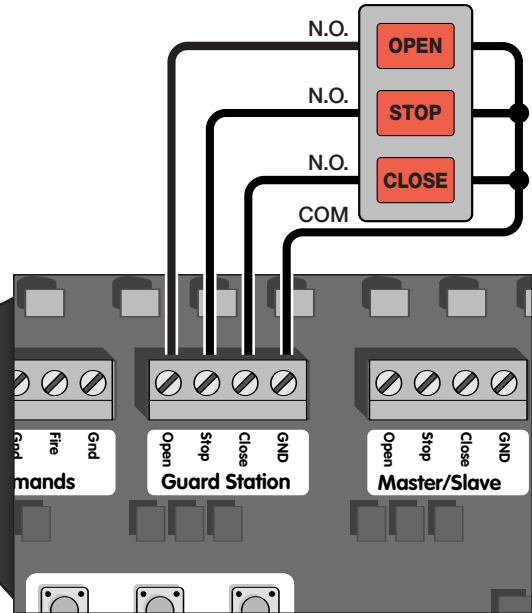

Guard Station

The guard station provides control of the gate operator to open, stop and close the gate.

All three switches must be Normally Open type of switch, and can share the same common (ground).

Place the control switch box within sight of the gate, away from moving parts of the gate and out of reach of children.



SPECIAL FEATURES

Auto-Open Feature

The Auto-Open feature in Viking Gate Operators enables the following functionality in the event of power failure:

- Open the gate in case of power failure (120 or 220 VAC).
- Keep the gate at the open position as long as there is no power.
- Resume to normal operation when the power has been restored.

The Auto-Open feature allows proper operation while opening in case of power failure for the following devices:

- All accessories,
- All safety devices,
- All entrapment protections.

The only operation that can not be executed while opening in case of power failure is to CLOSE the gate.

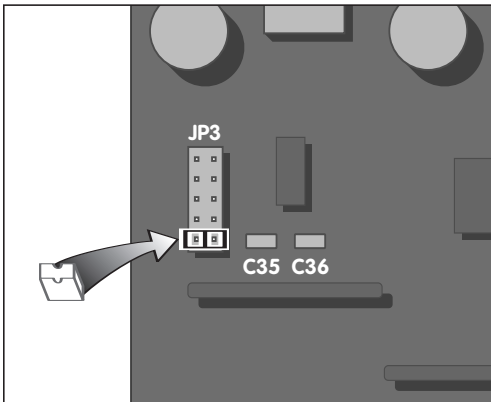

To enable the Auto-Open feature : Use the “jumper” provided and place it on the pin-header of JP3, on the terminals close to C35 as the illustration indicates.

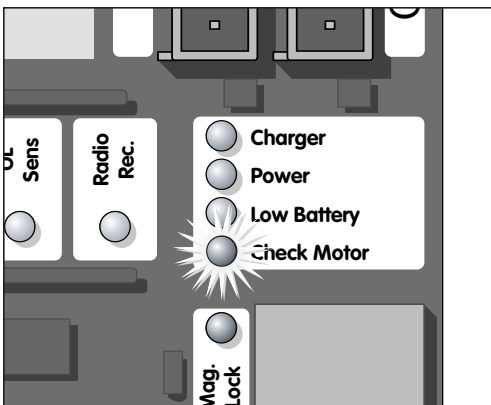

Once you put the “jumper” on the control board the “Check Motor” light will come on indicating that the Auto-Open feature has been enabled.

SPECIAL FEATURES

Intelligent Obstruction Sensor (Primary Entrapment Protection)

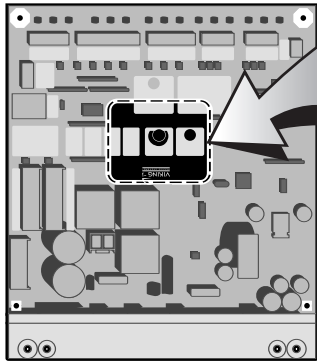

Trim Pot Location

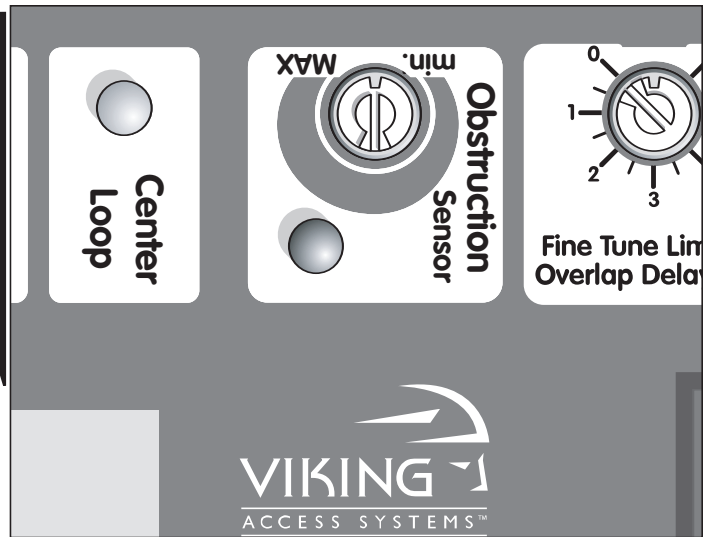

Turning the Trim Pot clockwise increases the sensitivity.

Turning the Trim Pot counter-clockwise decreases the sensitivity.

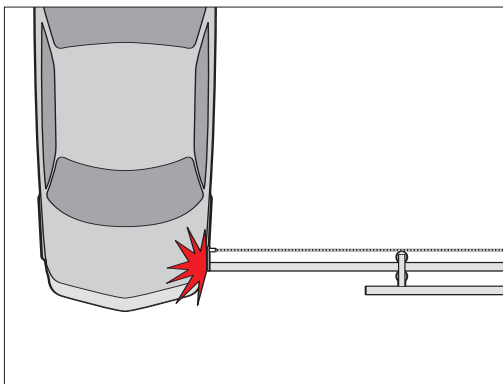

The Obstruction Sensor detects obstructions in the path of the traveling gate. The Trim Pot for the Obstruction Sensor adjusts the sensitivity level that triggers the Sensor.

When the Obstruction Sensor detects an obstruction it will:

1. Stop the gate's movement and reverse it momentarily.
2. Bring the gate to a resting position.
3. Disable the Hold Open Timer feature until the Gate Operator receives a new command.

If another obstruction is detected before the gate reaches either limit it will:

1. Stop the gate's movement.
2. Bring the gate to a resting position.
3. Disable the Gate Operator.

UL325 standard requires an audio alarm to go off after two consecutive entrapment events sensed by the Inherent Entrapment Protection of the Gate Operator.

The audio alarm will sound for a period of 5 minutes or until the "Stop" Button is pressed (see page 8 for remote installation of a "Stop" Button).



SPECIAL FEATURES

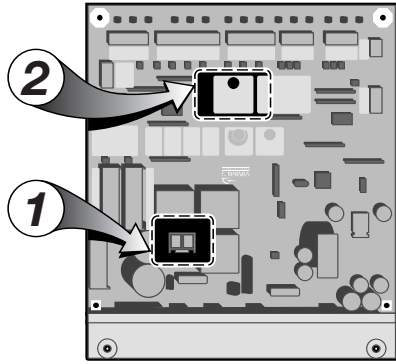

Connection Locations

Fail Safe/Fail Secure Operation

The gate operator contains a unique design that allows the user to move the gate manually in case of power failure.

There are three levels of force required to move the gate manually.

Fail Safe:

By removing the wire-jumper plug from the “Fail Safe/Secure” connector:
The gate can be move manually with relative low amount of force.

Fail Secure:

By inserting the wire-jumper plug into the “Fail Safe/Secure” connector:
The gate can still be move by hand with relative high amount of force.

In case of faulty operation or power failure, remove the cover, locate the Reset Switch and turn it to the “OFF” position. The gate can now be pushed manually.

At the end of operations, turn the switch to the “RESET” position to resume normal operation.

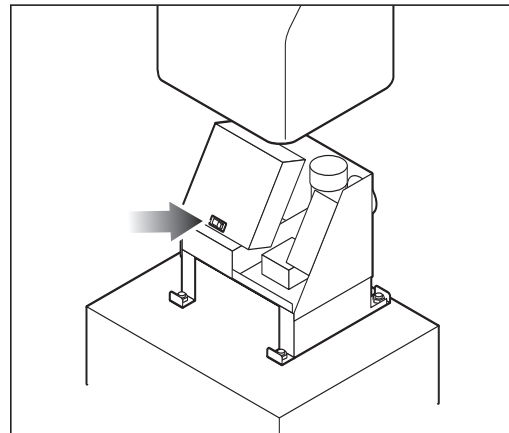
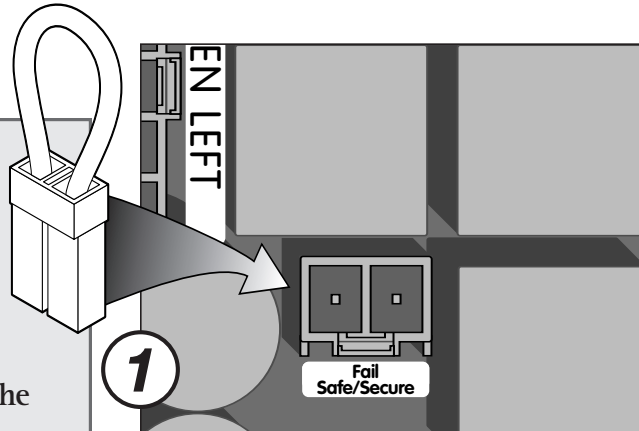

Hold Open Timer

The Hold Open Timer function holds the gate at the open position for a predetermined amount of time, prior to closing automatically. Set the Timer to the desired time, from 1 to 60 seconds.

If this feature is not needed, turn the Trim Pot clockwise to the “off” position.

Note: The Hold Open Timer affects the “radio receiver command” and the sequence of operation for the gate (see page 24).

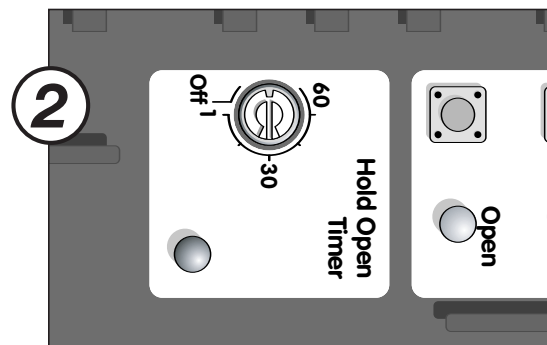

OPTIONAL VIKING BLUE INSTALLATION

WARNING – Connecting the plug backwards can result in damage to the Control Board and will render the Viking-Blue Module useless.

VikingBlue Wireless Master/Slave

1. Decide which Operator will be the Master and which will be the Slave.
- 2a. Install the “Master” Viking Blue Module on the Master Control Board.
- 2b. Install the “Slave” Viking Blue Module on the Slave Control Board.

Use care in connecting the plug to the Control Board. The pins are small and easily bent. Match the white dot on the plug to the white dot on the control board (near the JP2 legend as depicted).

3. Install the Jumper (near the JP3 legend depicted). Viking-Blue requires this jumper to operate as a Master/Slave device. The “Low Battery” LED will turn ON, indicating the Control Board is ready for use with the Viking-Blue Module.
4. Attach the Viking-Blue Module to the Operator. For better communication and performance follow these guidelines:
 - The Module must be under the Operator Cover.
 - The Modules must be facing each other as much as possible.

The Light on the Viking-Blue module will turn green upon connection between the other Module. Be sure to test your Master/Slave communication.

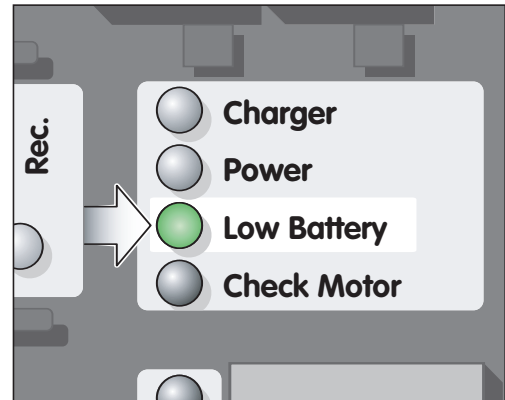
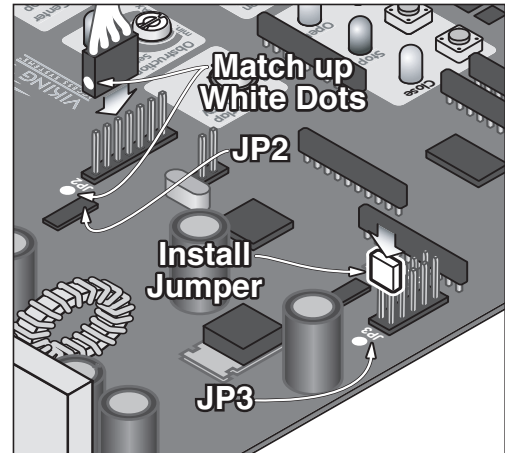

OPTIONAL SOLAR PANEL INSTALLATION

For Viking Vehicular Gate Operators

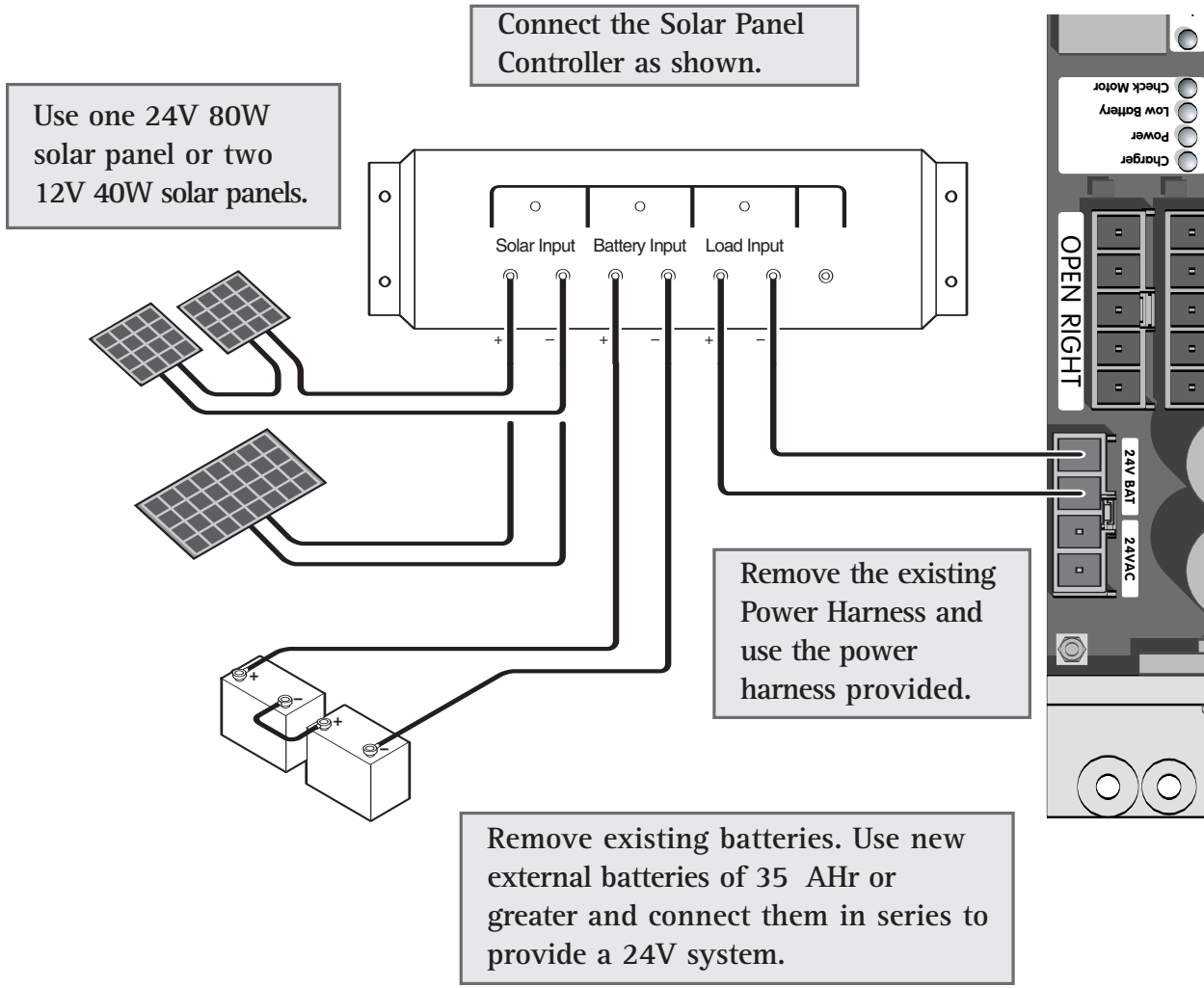

SOLAR PANEL INSTALLATION

For Viking Vehicular Gate Operators

WARNING – Solar Panel must be UL Listed, Class 2

STEP 1

Use a 24V solar panel or two solar panels of 12V in series with a total capacity of 80 Watts..

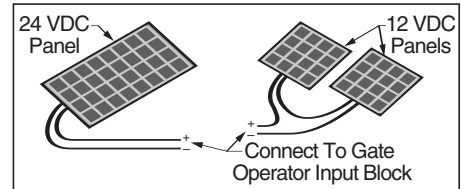

STEP 2

Connect the solar panel cables to the power harness as shown. Make sure you cut the wires coming from the toroidal transformer.

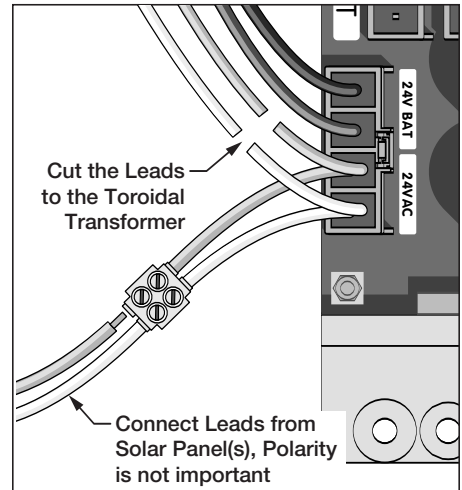

STEP 3

Replace the existing batteries with a battery pack of 35Ahr or greater.

STEP 4

Refer to the maps provided to get an idea about the number of cycles the gate will be operated per day. This figure is for a single gate operator with just:

- One Radio receiver,
- One low voltage low current loop detector and
- One low voltage, low current photo cell

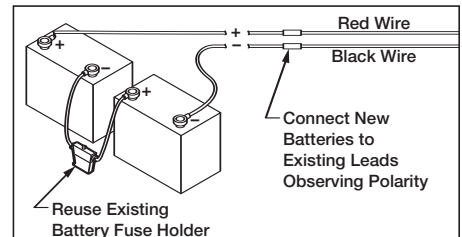

Number of Cycles per Day*

- 14
- 12
- 10
- 8
- 5
- 2

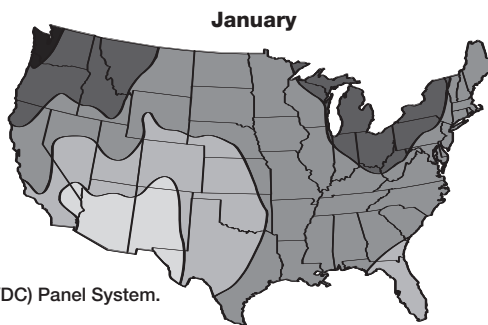

January

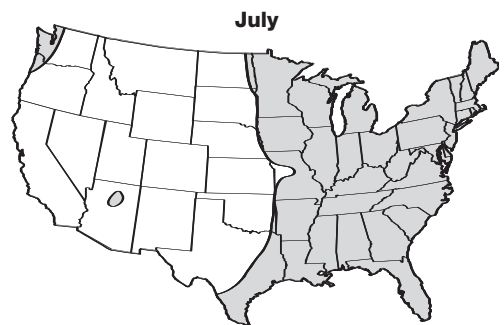

July

*With a 80 Watt (24VDC) Panel System.

1. The greater capacity of the batteries, the longer the system will operate on cloudy days.
2. If more specific information is needed, please consult with Viking Access Systems. For more information regarding solar energy refer to <http://www.nrel.gov>.



VIKING PIPE STAND

For Viking K-2 Vehicular Gate Operator

Standard Features

- Main pieces made of 1/4" thick material
- Includes Positioning Bar to aid in the installation process
- All hardware included

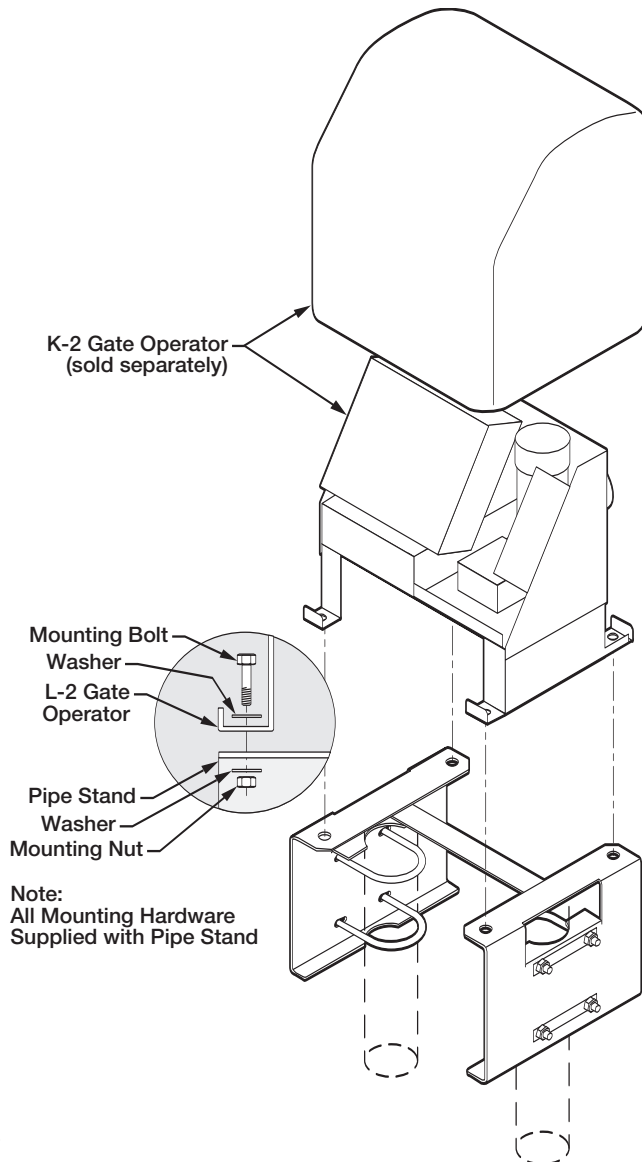
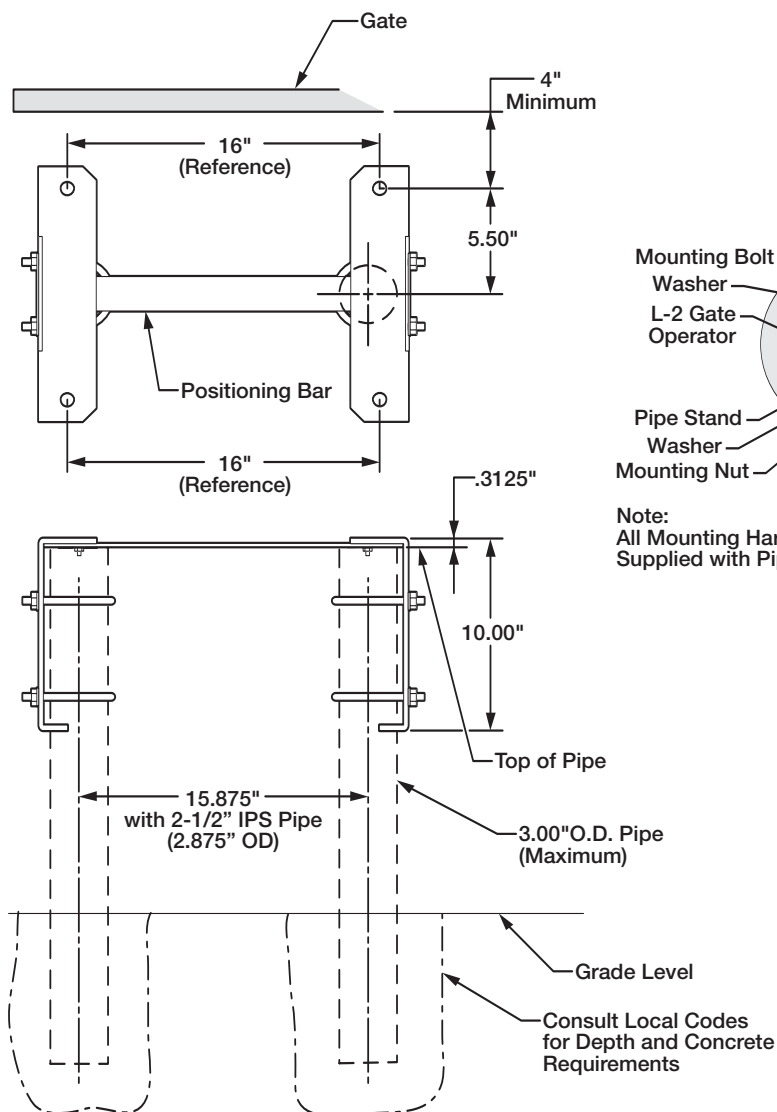

Note:
All Mounting Hardware
Supplied with Pipe Stand

When installing the Pipe Stand Assembly be sure it is parallel to the gate and that both sides are positioned square to each other and level. For further details see page 10 & 11.

VIKING PEDESTAL STAND

For Viking K-2 Vehicular Gate Operator

Standard Features

- Main pieces made of 1/4" thick material
- All hardware included

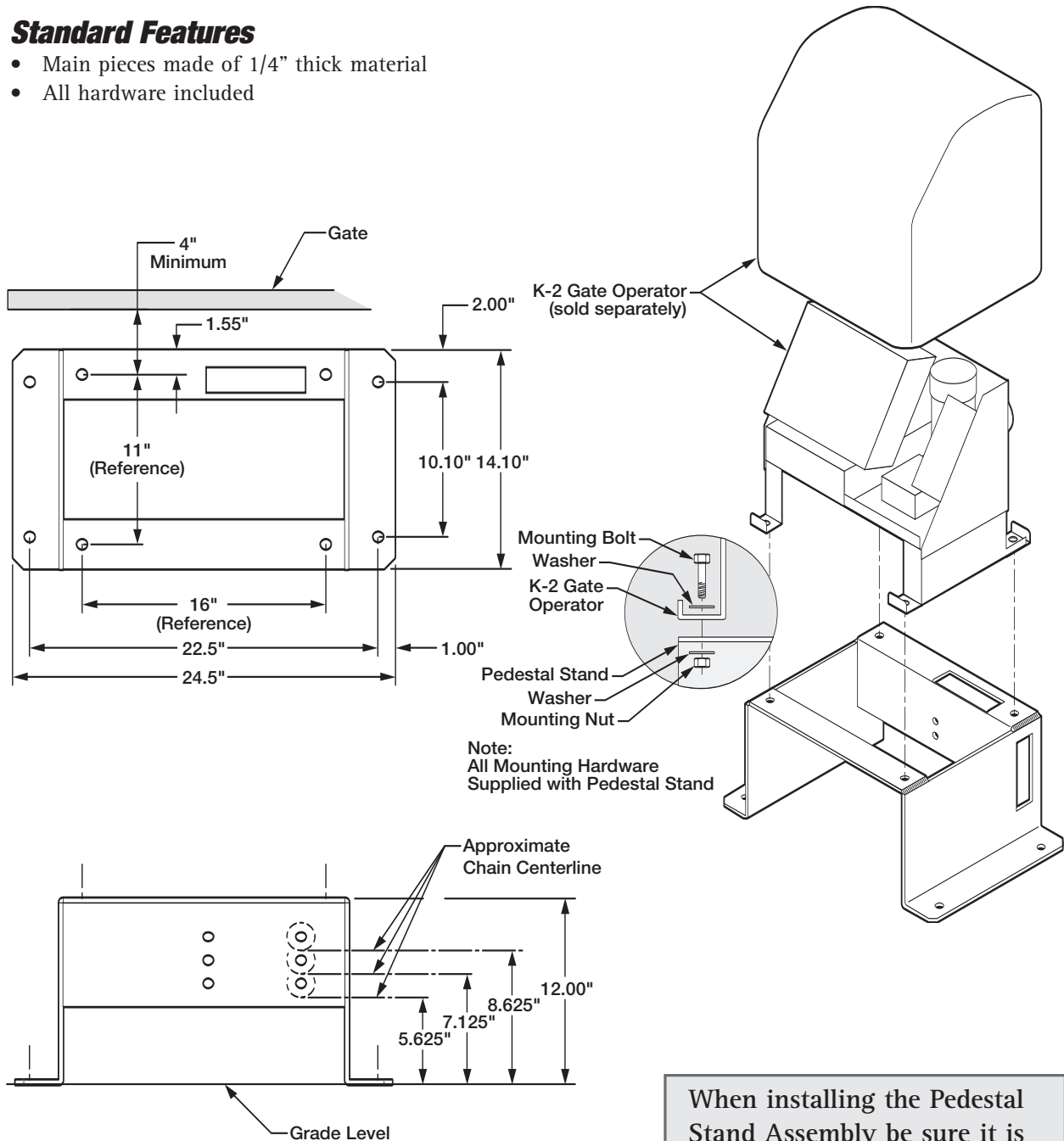

When installing the Pedestal Stand Assembly be sure it is parallel to the gate and that it is positioned square level. For further details see page 10 & 11.



OPTIONAL VIKING BLUE INSTALLATION

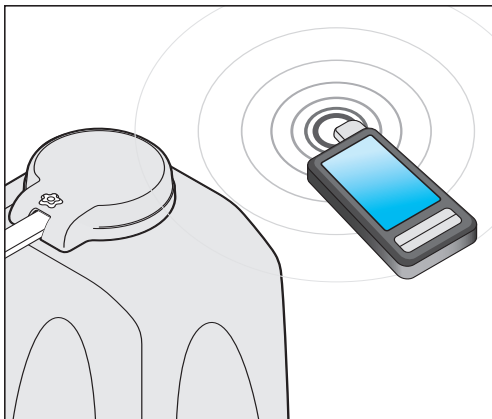
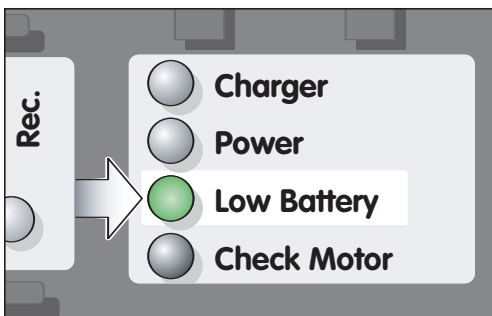
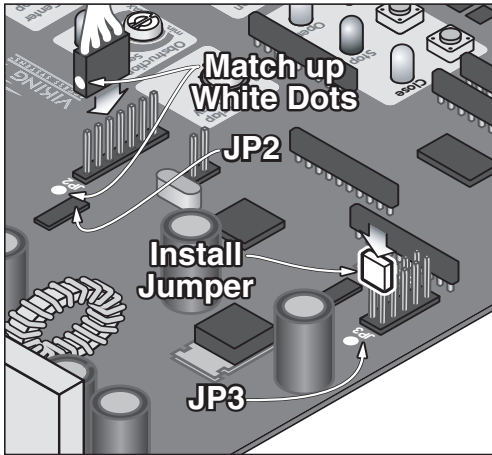

1. Insert CD into host computer
2. Install MS ActiveSync (check your computer, it may already be installed to communicate with a PDA or smart phone).
3. Install Viking Blue software
 Select Install Viking-Blue for PC (to have the computer to communicate with the Operator)
 Select Install Viking-Blue for PDA (to have the PDA to communicate with the Operator)

WARNING: If this PDA is a new device, turn off all options when syncing with the computer. For either installation, follow the steps in the user manual.

4. Plug the Viking Blue Module into the Viking Gate Operator Control Board.

WARNING: Connecting the plug backwards can result in damage to the Control Board and will render the Viking Blue Module useless.

Use care in connecting the plug to the Control Board. The pins are small and easily bent. Match the white dot on the plug to the white dot on the control board (near the JP2 legend as depicted).

5. Install the Jumper (near the JP3 legend depicted). Viking-Blue requires this jumper to operate. The “Low Battery” LED will turn ON, indicating the Control Board is ready for use with the Viking-Blue Module.
6. Open Viking Blue software on the chosen device.

If you are using the computer:

- Hold the computer near the Gate Operator.
- Run the application by clicking the icon on the desktop.
- Select “Setting” in the top right of the screen.

If you are using a PDA:

- Hold the PDA near the Gate Operator.
- Select “Start” and “Programs”.
- Click the Viking-Blue Application.
- Select “Connection” on the toolbar.

- Click “Search” (looking for available Viking devices).
- Select the Operator you want to communicate with.
- Click “Connect” to start communication. The Light on the Viking-Blue module will turn green upon connection to the Computer or PDA.

Follow the steps in the user manual.



TROUBLESHOOTING

Gate does not run – Check motor indicator comes ON

Check all motor connections to be fully engaged. Refer to page 15 and 16.

Ensure that the motor connections are:
a) Properly connected, Refer to page 15.

Check that all motor cable connections, junctions and extensions are properly connected and color-coded. Refer to page 15.

Check the 15 Amp fuse in the control board.

Ensure that the manual reset switch is at the 'reset' position. Refer to page 7 and 28.

Gate does not run – Check motor indicator is OFF

Check all motor connections to be fully engaged. Refer to page 15.

Check that limit switches are connected to the common and the normally close position. Refer to page 16.

Check that the stop command is not active. Refer to page 8 and 25.

Check that the UL command (photo beam and/or edge sensor) is not active. Refer to page 6, 7 and 23.

Check that the vehicular loop detectors are working properly. Refer to page 20, 21 and 23.

Check that the radio command is not active. Refer to page 24.

Ensure that you external accessories are working properly.

Check the 4 Amps fuse in the control board

Ensure that you power cables are adequate in voltage and properly connected. Refer to page 14.

Gate does not run – Power failure

Check the 15 Amp battery fuse.

Check the battery connections and cables.

Check the voltage of the battery.

Gate does not run – Obstruction sensor ON and audio alarm is SOUNDING

Ensure that the gate path is clear of obstructions.

Note: To stop the audio alarm, use the stop command. Refer to page 8 and 25.

Adjust the trim pot of the obstruction sensor. Refer to page 27.

Gate runs, stops and reverse momentarily – Obstruction sensor ON and audio alarm OFF

Ensure that the gate path is clear of obstructions.

Check for proper functionality and lubrication of the gate and hardware (hinges and the like).

Adjust the trim pot of the obstruction sensor. Refer to page 27.

Gate ignores the limit switches

Check that the open limit switch and close limit switch are in the corresponding place. Refer to page 16.

Check that all motor cable connections, junctions and extensions are properly connected and color-coded. Specifically check the blue and black motor leads. Refer to page 16.

Check that the limit switch is not faulty

Check that wires to the limit switch are not shorted.



TROUBLESHOOTING

Gate does not open or close

Check all motor connections to be fully engaged. Refer to page 15.

Check that limit switches are connected to the common and the normally close position refer to page 16.

Check that the stop command is not active. Refer to page 8 and 25.

Check that the UL command (photo beam and/or edge sensor) is not active. Refer to page 6, 7 and 23.

Check that the vehicular loop detectors are working properly. Refer to page 20, 21 and 23.

Check that the radio command is not active. Refer to page 24.

Ensure that you external accessories are working properly

Automatic close does not function

Check that the trim pot of the hold open timer is set to the proper time delay. Refer to page 28.

Note: Hold open timer closes the gate automatically once the gate reaches the limit open. The time delay to close is set by the trim pot. To turn this system off turn the trim pot all the way clockwise

- Make sure gate is fully open
- Check photobeam path for obstruction
- Check photobeam power
- Check loop detectors for proper function

Gate opens in the opposite desired direction

Verify your motor cable is connected to the proper connector. Refer to page 15 and 16.

Check that all motor cable connections, junctions and extensions are properly connected and color-coded. Refer to 15.

On a Master/Slave installation, one gate runs in the opposite direction

Check the motor and limit switch wiring. Refer to page 15 and 16.

Verify that one unit is connected as open-left and one unit is connected as open-right. Refer to page 15.

Verify the interconnecting wiring color codes match on both the master and slave boards. Refer to page 19.

Verify you are using shielded cables and that the shield is connected to the chassis ground at both ends, the master side and at the slave side.



TROUBLESHOOTING

Gate opens. Closes or stops on its own

Make sure that the 'Charger' LED is on and not flashing, indicating that there is AC power.

Check that your wires from your accessories are:

- Not shorting together
- Not shorting a power line
- Not shorting to metal or earth ground.

'Charger' LED off. Gate does not run - alarm sounds upon any input command

Check the 4 Amp fuse on the control board.

Check the 3 Amp fuse on the EMI control board. Refer to page 14.

Make sure the incoming AC line is properly connected. Refer to page 14.

Check the incoming high voltage power supply.

Check the proper selection of power supply (120/220 VAC). Refer to page 14.

Verify the EMI board by reading high voltage across the (4) blue and red wires at the terminal block connections.

Battery voltage reads zero or very low

Ensure the batteries are connected as follows:

- Left battery - Black terminal connected to the black wire from the harness (jacketed wire)
- Left battery - Red terminal connected to the red wire from fuse holder
- Right battery - Black terminal connected to the red wire from fuse holder
- Right battery - Red terminal connected to the red wire from the harness (jacketed wire)



our continuous commitment to excellence

Viking Access Systems is continuously working hard to identify and design products that will appeal to the industry and its needs. As technology continues to advance, we have developed a completely efficient and intelligent line of gate operators to meet the changing demands. These machines offer; full UL325 and UL991 compliance, soft-start and soft-stop, intelligent obstruction sensors, continuous operation (100% duty cycle) and extreme power efficiency. Innovative features include; adaptive and self-learning algorithms, redundancy design in both hardware and software to ensure operation and functionality, protection from lightning, short circuit and power surges, and our exclusive helical gearing offering the highest efficiency rating in the industry. Our entire product line is continually modified and improved based on the latest technology and our customer's valuable feedback. The results are products that offer accuracy, efficiency, reliability and performance, all in sleek, high-tech designs.

We pledge to continue establishing ourself as the leader in high quality, innovative gate operators by developing "Next Level" technology. We are committed to providing safety and convenience with innovative solutions for every security gate need.



VIKING ACCESS SYSTEMS™

standard features

and operator specifications

UL325 and UL991 Listed by Underwriter Laboratories (UL) • Accessible manual emergency release • Fail-Safe option sets the gate to automatically transfer to a fail-safe mode in the event of a power failure, allowing the gate to be pushed open without the use of special knowledge of the equipment • Fail-Secure option sets the gate to mechanically lock in the event of a power failure, allowing no manual movement without the use of the manual release • Standard Auto Open feature • Elegant design, appealing to any architectural project • Powder coated aluminum chassis • Opening up to 27' • Operation speed of one foot per second • 100% duty cycle under very wide temperature range • Very low power consumption • 100 cycles of operation on backup battery (700 lb. gate and 20' length) • Intelligent speed control with smooth start and stop, self-adjust system • Modulated speed regulator prevents exceeding operating speed that may reduce the service life of the gate operator and/or installation • Intelligent obstruction detection with adjustable sensitivity • Innovative fine tune adjustment for the end of gate travel (down to 1/8") • Built-in protection against lightning strikes or similar electrical surges • Inherent overload protection in the regulated power supply for external accessories with multiple devices of protection • Modular connectors for easy installation • Solar panel and low voltage wiring compatibility • LED indicators for verification of operation



Viking Access Systems
Phone 800.908.0884 Fax 949.753.1640
631 Wald Irvine, CA 92618

www.vikingaccess.com